

Digi-Star★

EZ3600 Operators Manual

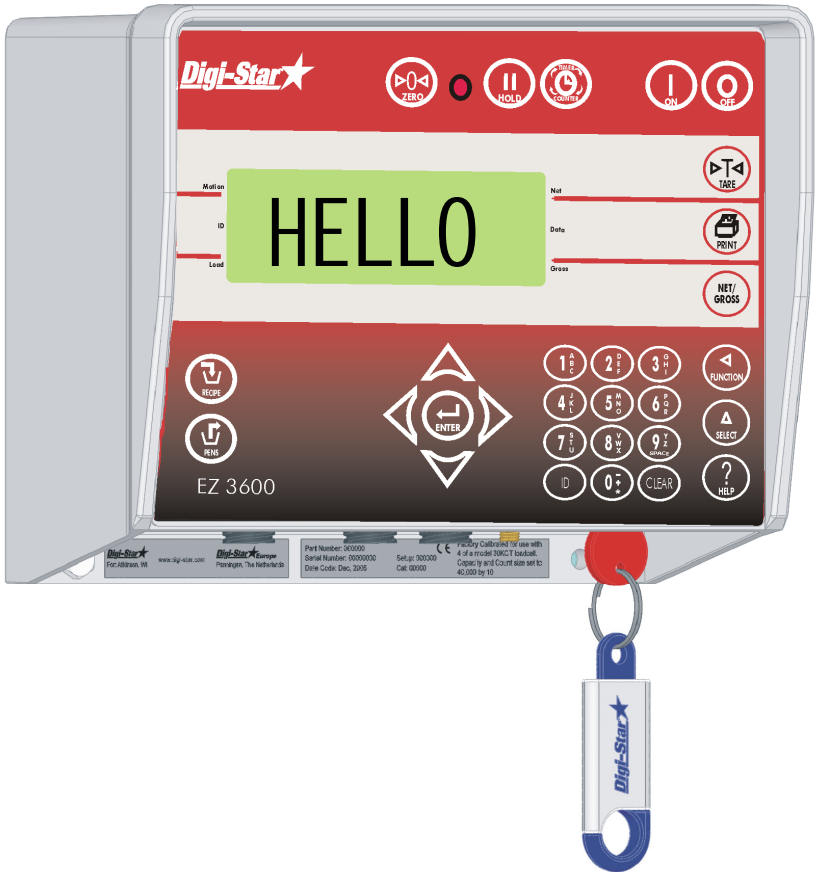

Digi-Star★

Ft. Atkinson, Wisconsin USA

Digi-Star★Europe

Panningen, The Netherlands

www.digi-star.com

TABLE OF CONTENTS

TABLE OF CONTENTS	2
FEED MANAGEMENT SOFTWARE	4
CAB CONTROL (WIRELESS)	5
BEFORE CHARGING BATTERY OR WELDING	6
INDICATOR OVERVIEW	7
OPERATION	9
TURN ON INDICATOR	9
DATA TRANSFER	10
DATAKEY MODE	10
RF DATALINK MODES	10
INDICATOR DATA FORMATS	11
LOADING AND FEEDING	11
COMPLETE LOADS MODE	11
STARTING A RECIPE	11
LOADING RECIPE	13
UNLOADING TO PENS	13
RECIPE AND PEN LIST MODE	14
STARTING A RECIPE	14
RESIZE RECIPE WEIGHT	14
LOADING RECIPE	15
UNLOADING TO PENS	15
ADVANCED COMMANDS	16
UNLOAD PARTIAL PENS	16
GO BACK TO SKIPPED INGREDIENT	16
CHANGE FEEDING NUMBER	17
CLEAR INDICATOR MEMORY	17
RE-USE RECIPE/PEN DATA	18
ADD A PEN TO PEN LIST	19
HOLD	20
PRINTING	20
BACKLIGHT INTENSITY	20
COMMONLY USED DIRECT ACCESS NUMBERS	21
PRE-ALARM	21
AUTO INGREDIENT / MANUAL PEN ADVANCE	21
AUTO ADVANCE	22
TOLERANCE	22
PEN TOLERANCE	22
DELAY TIME	22
DRIVE RATIO	23
SCALE ID OR TRUCK ID	23
RADIO NUMBER	24
RESIZE OPTION	24
CHANGE TIME	25
CHANGE DATE	25

DIRECT ACCESS NUMBERS LIST26

- MENU 1. BASIC FEATURES IN MOST INDICATORS26
- MENU 2. CLOCK, PRINTER, COMM. & WEIGHT FEATURES ...26
- MENU 3. SCALE CALIBRATION SETTINGS27
- MENU 4. PRESET, BATCHING & COUNTER FEATURES.....27
- CALIBRATION28

TROUBLESHOOTING.....29

INSTALLATION31

- INDICATOR MOUNTING.....31
- LOAD CELL DIRECTION31
- CONNECT LOAD CELLS TO J-BOX33
- CHANGE SETUP AND CALIBRATION NUMBERS.....33

OPTIONAL EQUIPMENT34

- ROTATION COUNTER SENSOR34
- TRANSMITTER/RECEIVER34
- REMOTE INDICATORS34

FEED MANAGEMENT SOFTWARE



A full featured Windows[®] based system that offers powerful features that are easy to use.



Entry level system easily upgraded.
Based on features of TMR Tracker



Remote site monitoring software.
Works with email service to connect
Tracker to remote location



Front-end tool for beef feeding customers
to enter ingredient, recipes, corral and
wagon information.

For additional information go to www.digi-star.com

CAB CONTROL (WIRELESS)



Features

- Wireless remote with full key control of indicator on mixer
- Mount remote in easy view of loading
- Improves loading accuracy

Functions

- Communicates with multiple mixers
- Easily call-up recipes without leaving loader

Specification

- Internally mounted 2.4 GHz radios
- Up to 1000 foot range
- 24 channels
- 12 or 24 volt DC system

For additional information go to www.digi-star.com

BEFORE CHARGING BATTERY OR WELDING

Important Precaution



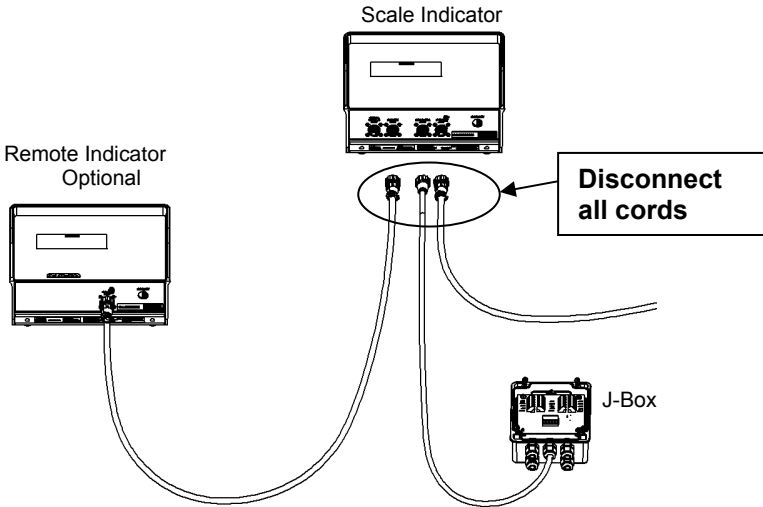

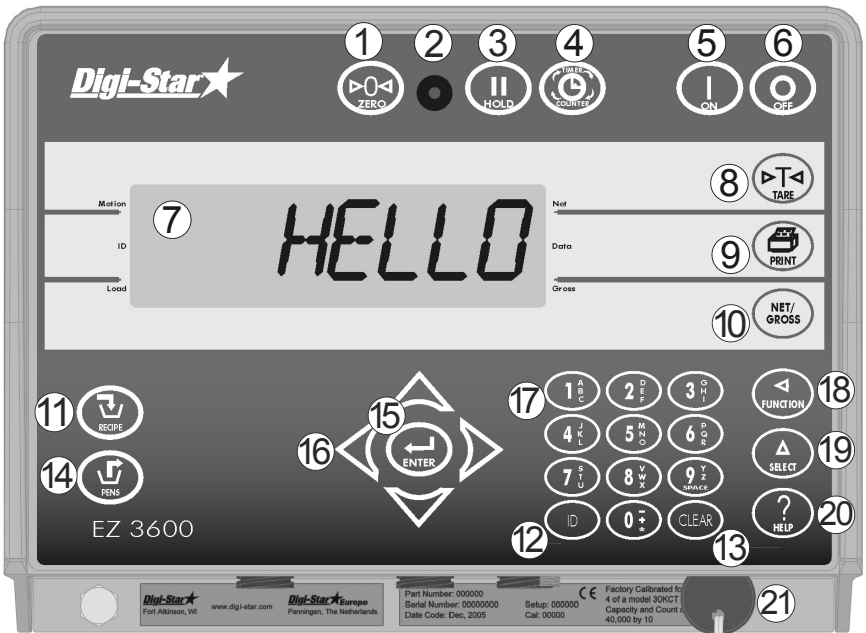

**Disconnect all indicator leads before charging battery or welding.
Damage may occur to indicator and load cells.**













INDICATOR OVERVIEW



Note: See pages 31-33 for installation instructions

- ①  – press and hold for 3 seconds to zero balance.
- ② **Pre-Alarm Light** – flashes and alarm sounds when weight is within preset limit.
- ③  – holds displayed weight when moving machine.
- ④  – not used.
- ⑤  – turns indicator on. Press while on to run self test.
- ⑥  – turns indicator off.
- ⑦ **Display Window** – Displays current actions.
- ⑧  – temporary zero (Net Mode).

- 9  – records to memory or prints displayed weight.
- 10  – toggles between Net and Gross weights.
- 11  – selects recipes in memory.
- 12  – enters user number and feeding number. Any number can be used for user until number assigned by management software.
- 13  – clear (backspace).
- 14  – press in List Mode to begin pen unloading. See page 15.
- 15  – accepts change or proceeds to next item.
- 16 Directional Arrows - moves through list of information.
- 17 Keypad – inputs numbers or letters.
- 18  – performs task displayed by select.
- 19  – displays additional tasks.
- 20  – press for additional information.
- 21 DataKey –transfers data between computer and indicator.

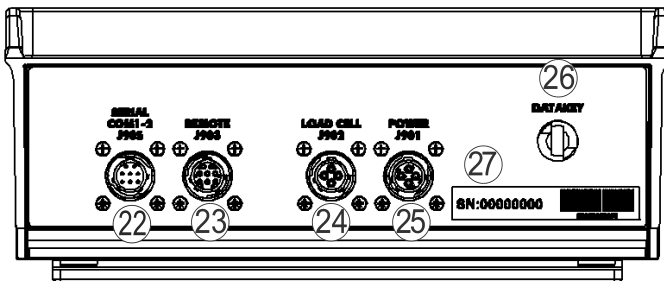

- 22 Serial/Printer Port – optional, communicate with computer and other digital input/output devices.
- 23 Remote Port - optional remote display.
- 24 Load Cell Port – for J-Box cord.
- 25 Power Port– for Power Cord.
- 26 DataKey Port– for DataKey insertion. Turn DataKey to upload/download data.
- 27 Serial Number Plate – Serial Number of indicator.

See pages 31-33 for installation instructions.

OPERATION

Turn on indicator



1. Press .



1. Enter user number if required.
2. Press .

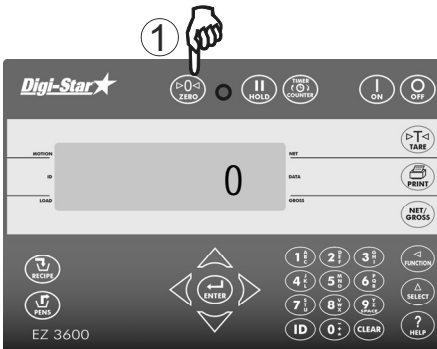

1. Press and hold  for 3 seconds to zero balance indicator.

DATA TRANSFER

DataKey Mode





1. Insert DataKey into indicator.

2. Press  to upload data.

Note: If indicator displays uncompleted data in memory, press  to overwrite data. Remove DataKey when transfer complete.

To download complete data: Insert DataKey, indicator automatically sends data to DataKey. Remove DataKey.

RF DataLink Modes

Operation	Message
DataLink connects with indicator	←PC→
DataLink sends data to indicator	DL←IN
Indicator receives data	ALL FEED LINES RECEIVED -PRESS RECIPE KEY TO CONTINUE
Data compete, indicator sends data to DataLink	←PC→
Data sending	DL→OUT
To send data to PC if operator does not complete all feeding at end of feeding schedule. Press  until display shows message (right column), press  to select	EZ→PC
The indicator marks uncompleted data as completed and sends feeding data to DataLink.	

Note: After sending, uncompleted data erased.

Indicator Data Formats

Data sent to indicator sent in two formats:

Complete Loads Mode: Each load built by PC software. It assigns pens to recipe and builds exact load for pens.

Recipe and Pen List Mode: PC software sends recipe data and pen data in two different fields. Operator selects recipe to build and pen deliveries.

LOADING AND FEEDING COMPLETE LOADS MODE

Starting A Recipe



1. Press .



1. Indicator scrolls feeding number, first recipe and pen number.

2. Press  and  to find desired recipe.

3. Press  to select recipe shown.

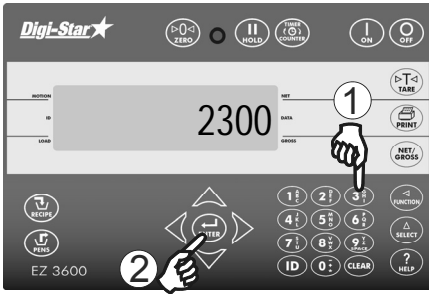

Indicator gives option to resize pen weight.

1. Enter new weight or keep original weight.
2. Press .



Note: Press  to resize by number of head in pen.

Note: Press  to accept pen values without resizing.

Note: If indicator gives warning resized amount is over capacity, press  to override.

Loading Recipe





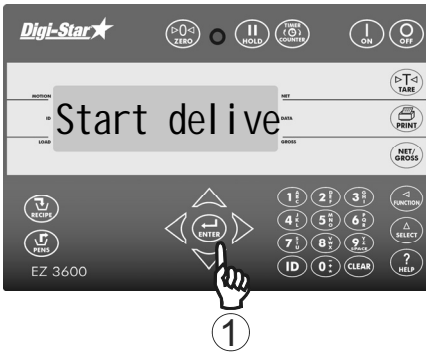

1. First ingredient weight flashes in display. Load ingredient.
2. Weight approaches zero, alarm will flash and sound.
3. a. Manual Advance: Weight reached, press  to accept. Press  again to start next ingredient.
3. b. Auto Advance: When preset weight reached, indicator advances to next ingredient.



Unloading to Pens



Ingredients loaded, indicator displays first pen to unload.

1. a. Manually Advance: Press  to go to pen. When weight reached, press  to accept. Press  again to start next pen.
- or
1. b. Auto Advance: When preset weight reached, indicator advances to next pen.

Note: Do not press .

Note:
 If different pen needed press 
 or  to find desired pen.
 Press  for pen delivery.

Last pen complete, indicator displays "Recipe Complete".

RECIPE AND PEN LIST MODE

Starting a Recipe





1. Press .

2. Display reads:

Example:

RECIPE DRYCOW TOT- 2500

3. Press  and  to select recipe,  to start.

Resize Recipe Weight



Indicator will display: resize, then the resize weight.

1. Enter desired recipe weight.

2. Press , indicator resizes ingredients to recipe's total weight and displays first ingredient to load.

Note: Indicator warns resized amount over capacity, press  to override.

Loading Recipe



1. First ingredient and weight flash in upper display. Begin loading ingredient.
2. Weight reached, alarm will flash and sound.
3. a. Manual Advance: Weight reached, press . Press to start next ingredient.

or

3. b. Auto Advance: When preset weight reached, indicator advances to next ingredient.

Unloading To Pens

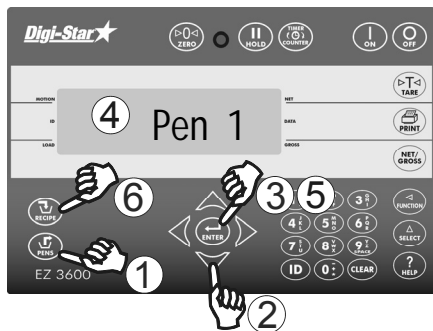

1. When ingredient loading complete, display reads "Recipe Complete". Press . Indicator displays unloading pens.

2. Press or to select desired pen.

3. Press .

4. Pen and weight displayed, begin unloading to pen.

5. a. Manual Advance: Weight reached, press to accept. Press again to start next pen.

or

5. b. Auto Advance: When preset weight reached, indicator advances to next pen.

6. When unloading is complete press to start next recipe.

ADVANCED COMMANDS

Unload Partial Pens

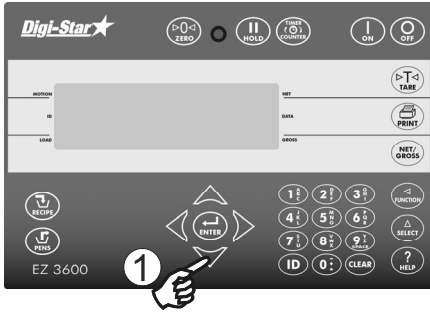

1. Press  to advance to next pen without finishing current pen.



Note: If pen tolerance is set and feeding stopped before preset weight reached, alarm sounds, indicator displays:

Pen Underfed — Press Print
To remove pen from list-
Press on to keep pen

See page 22 for Pen Tolerance set-up.

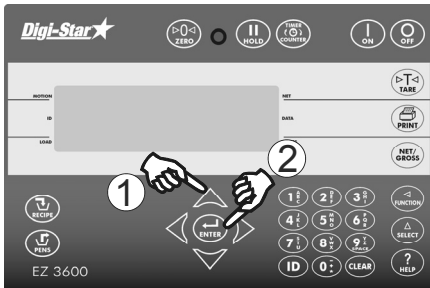
Go Back to Skipped Ingredient



1. Press  or  to move back.

2. Press .

Note: Ingredient weight changed more than 4 display counts cannot restart that ingredient.

Example: If minimum display change is 10 lbs/kgs, more than 40 lbs/kgs, cannot restart that ingredient.

Change Feeding Number

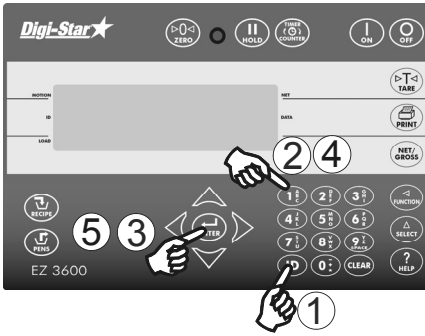

1. Press **ID**.
2. Enter user number.
3. Press **ENTER**.
4. Enter feeding number (1-9).
5. Press **ENTER**.







Clear Indicator Memory



1. Press **OFF**.
2. Press and hold **CLEAR**.
3. Press **ON** while holding **CLEAR**
indicator scrolls:
On=Clear Clear=Reuse
Net=exit.
Release **CLEAR**.
4. Press **ON**.

Re-Use Recipe/Pen Data



1. Indicator .
2. Press and hold .
3. Press  while holding  indicator scrolls:
 On=Clear Clear=Reuse
 Net=exit.
 Release .
4. Press  again to re-use recipe and pen data.

Note: Re-use data stored in indicator, takes recipe and pen information and removes completed weights loaded or unloaded and marks them undone. Won't accumulate data day to day. Download data to DataKey before re-using recipe and pen data stored.

Note: For continuous re-use, set D.A.N. **466** to on. See page 28.

Add a Pen to Pen List



Enter pen name or number.

1. Press .

2. Press to add pen.



1. Press or to find desired recipe.

2. Press .



1. Enter amount to unload to pen.

2. Press .

1. Enter number of animals / pen.

2. Press .



1. If zones are active display reads:

“Enter Zone 0-9”

2. Press .

Hold

Hold mode prevents displayed weight from changing while moving.



1. Press  holds displayed weight.

2. Press  returns indicator to normal.

If weight is added while in hold mode, press  to cancel hold.

PRINTING

Note: Optional serial port must be installed for printing.



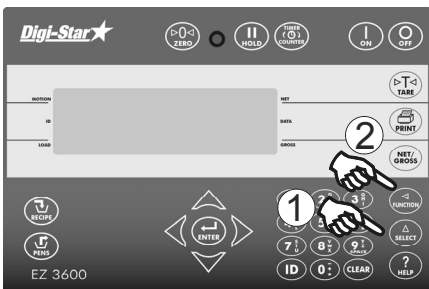

1. Reference technical manual D3648 at www.digi-star.com.

Backlight Intensity



1. Press  until dimmer is displayed.





2. Press  reduces backlight intensity by 60%. Press  again for full intensity.

COMMONLY USED DIRECT ACCESS NUMBERS

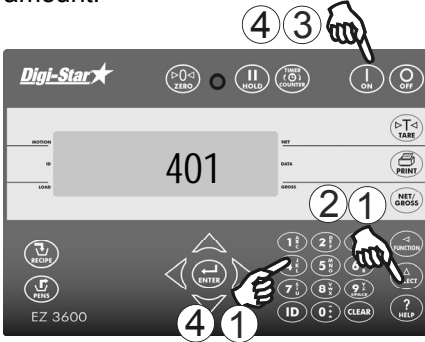
Pre-Alarm

Early warning, weight reaching amount.





1. Enter **401** and press .
2. Press  again to change between WEIGHT and PERCENT.
3. Press .
4. Enter Pre-Alarm value. Press .

Auto Ingredient / Manual Pen Advance

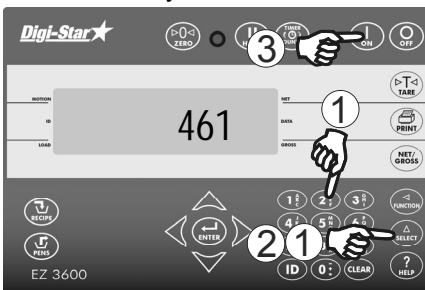
Ingredients automatically advance,
Pens manually advance.



1. Enter **461** and press .
2. Press  choose on/off.
3. Press .

Auto Advance

Allows hands free operation of programmed recipes. When auto advance feature activated, indicator automatically advances to next ingredient once tolerance, and delay time requirements met.

Tolerance

Sets weight “window” to accept loaded weight before auto advance.

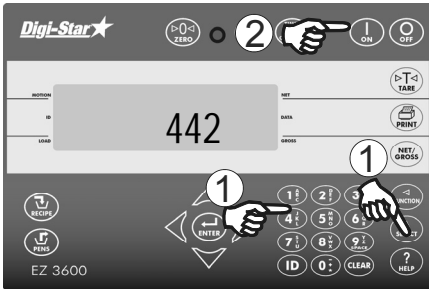

1. Enter **442** and press . Press again choose percentage settings:
OFF, 0.5, 1 - 5, 7, or 10.
2. Press .

Pen Tolerance

Available in List Mode Only

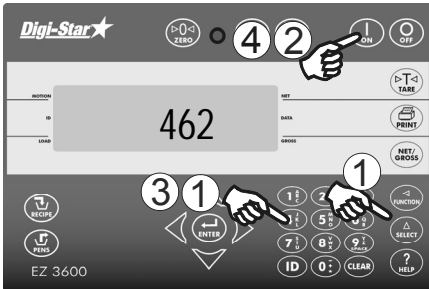

1. Enter **462** and press . Press again to choose weight or percent.
2. Press , screen will display “pentol”.
3. Enter weight or percentage desired.
4. Press .

Delay Time

Changes time indicator, waits before automatically advancing to next ingredient.

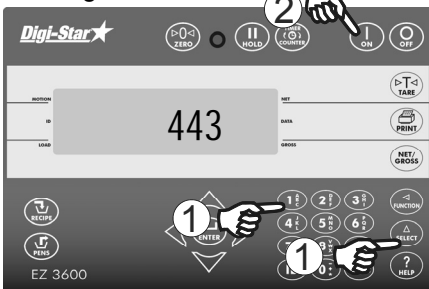

5. Enter **443** and press . Press for delay time (In seconds: Manual, 1, 2, 3, 5, 7, 10, 20, 30, or 60).
6. Press .

Note: Set to Manual prevents automatic advance.

Drive Ratio

Drive ratio is number of turns seen by sensor divided by number of mixer rotations.

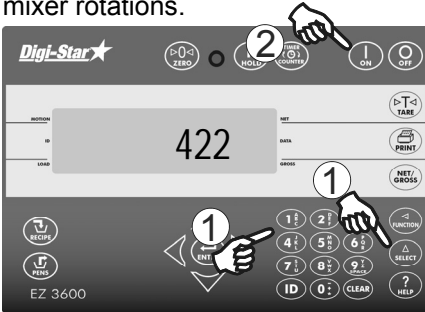

1. Enter **422** and press to enter drive ratio value.
2. Press .

Scale ID or Truck ID

Each indicator has scale ID.

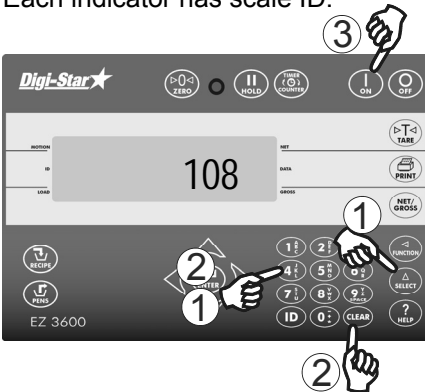



1. Enter **108** and press .
2. Press to erase old ID, enter the new ID.
3. Press .

Note: TMR Tracker or Diet Manager, software ID must match.

Radio Number

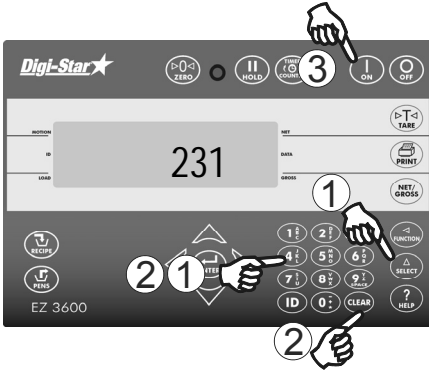
Used with cab control option.



1. Enter **231** and press .

2. Press  to erase number, enter new number.

3. Press .

Note: Do not use same number for two different indicators.

Resize Option

Make weight changes to pens unload weight or recipe load size.

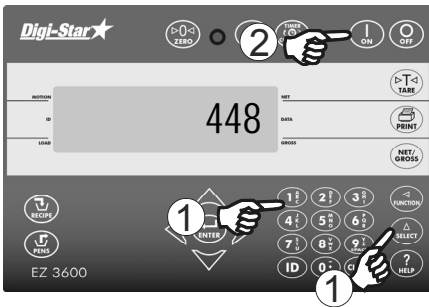





1. Enter **448** and press .

Press  again, change On/Off.

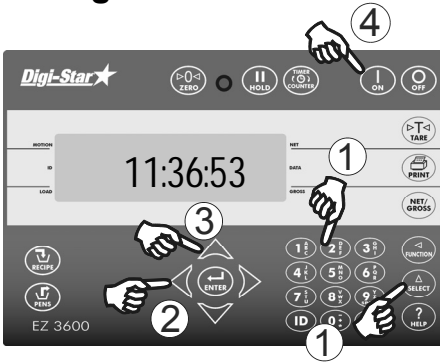
2. Press .





Change Time

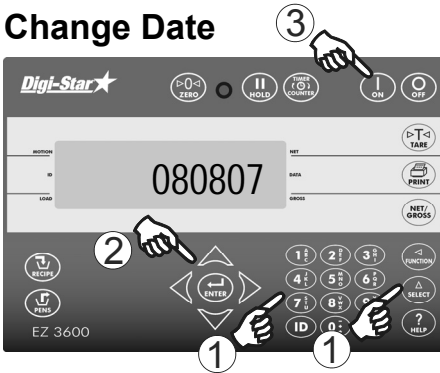

1. Enter **202** and press .
2. Press  arrow to move cursor.
3. Press  to set time.
4. Press .

Change Date



1. Enter **204** and press .
2. Press  arrow to move cursor. Format ddmmyy. Press  arrow to set date.
3. Press .

DIRECT ACCESS NUMBERS LIST

Enter D.A.N. press  displays setting name, allows value change.

Press  saves setting.

SETTING/ DISPLAY	D.A.N NO.	OPTIONS (BOLD=DEFAULT)	DESCRIPTION
MENU 1. BASIC FEATURES IN MOST INDICATORS			
LANGUAGE {langag}	101	English(ENGLISH) (NEDERL) French (FRANCS) Dutch(DEUTSH) Italian (I TAL) Portuguese (PORT) Spanish (ESPAN) Danish (DANSK) (MAGYAR) (VESTA)	Select language to be displayed.
TR HOLD { tr hld}	107	ON/OFF	Display gross weight if TR key is held for 3 seconds.
SCALE ID SETUP {scal id}	108	NEW EZ	Identity of scale location (truck id or Mixer number).
MENU 2. CLOCK, PRINTER, COMM. & WEIGHT FEATURES			
TIME FORMAT {time f}	201	24 HR AM/PM	Select time format -AM/PM or 24 hour
1 TIME {time}	202	XX:XX:XX	Select key changes time, function key chooses hh:mm:ss.
DATE FORMAT {date f}	203	1-mm-dd 2-mm/dd/yy 3-mm/dd/yyyy 4-dd-mm 5-dd/mm/yy 6-dd/mm/yyyy 7-ddmoyy 8-ddmoyyyy.	Select date format
DATE {date}	204	Enter XXXXXX	Select key changes date - function key chooses mm/dd/yy .
SCALE NUMBER SCL NO	231		Select scale number for cab control communication

SETTING/ DISPLAY	D.A.N NO.	OPTIONS (BOLD=DEFAULT)	DESCRIPTION
REMOTE DISPLAY RMDISP	234		Select type of remote display
MENU 3. SCALE CALIBRATION SETTINGS			
DISPLAY UNIT {lb-kg}	303	LB/KG	Display pounds -lb or kilograms - kg
MIMIC TYREL {tc1300}	321	OFF/ON	If ON -records preset weights like a TYREL TCX-1300 indicator. Indicator Tracks gross weight while batching.
MENU 4. PRESET, BATCHING & COUNTER FEATURES			
PRE ALARM {p mthd} & {p-alm} ..	401	WEIGHT PERCNT	Select weight or percentage method, then enter a value to activate an early warning that indicator is reaching the preset.
BUZZER buzzer	404	1-4, ON/OFF	ALARM BUZZER -allows user to turn off alarm horn.
TIMER/ COUNTER {tmrctr}	421	REV TIME	Select time or mixer revolutions to decrement mix timer/counter.
DRIVE RATIO {dratio}	422	0001.00	Enter the number of input pulses that equal 1 mixer revolution.
ENTRY METHOD E MTHD	441	1,2,3	Select batch 1-amount/animal 2-percent/load 3- amount/load
TOLERANCE {toler}	442	OFF ,.5,1-5,7,10	Select tolerance weight percentage to accept ingredient.
INGR. ADVANCE DELAY {delay}	443	MANUAL , 1- 3,5,7, 10,20,30,60	Select seconds to delay before advancing to next ingredient.
FORCE USER ID {userid}	446	ON/OFF	If ON -operator must enter user ID to use indicator.
RESIZE RECIPE {resize}	448	ON/OFF	If ON -operator can change recipe size.
RECIPE TOTAL {rectot}	451	ON/OFF	Selects total amount to be displayed when starting recipe.
TOLER OVER LOCK {overlk}	453	ON/OFF	If ON -prevents auto-advancing if preset exceeds tolerance

SETTING/ DISPLAY	D.A.N NO.	OPTIONS (BOLD=DEFAULT)	DESCRIPTION
FEED ZONE {fdzone}	454	ALL , 1-9	Select feed zone for recipe deliveries.
UNDONE RECIPES {undn 1}	455	ON/OFF	If ON -displays all incomplete recipes or enable if indicator is stationary mixer/batch when using Datalink.
AUTO START PENS {autpen}	458	ON/OFF	If ON -starts pens list after recipe is loaded in list mode format.
MANUAL PEN ADVANCE {manpen}	461	ON/OFF	If ON -overrides automatic advance for pens.
PEN TOL {t mthd} & {pentol}	462	WEIGHT PERCNT	Select weight or percentage method, then enter pen tolerance.
PEN WEIGHT {pen wt}	463	LOAD GROSS NET	Select method for displaying pen Weight -net, load, or gross.
DOUBLE KEY PRESS PREV {dbkey}	465	ON/OFF	Select method ignores double pressing of keys when advancing ingr. while loading mixer.
RECIPE REMAIN ACTIVE (RE-USE)	466	ON/OFF	Select ON to reuse recipes.
CALIBRATION			
SETUP NUMBER SETUP	871		Quick entry method selects weigh method 1-4lbs, 5-8 kg, gain 1-9, display counts 1-9 and capacity *1000
CALIBRATION NUMBER CAL	872		Weight displayed at 0.4mV/V for these load cells

TROUBLESHOOTING

FLOW CHART

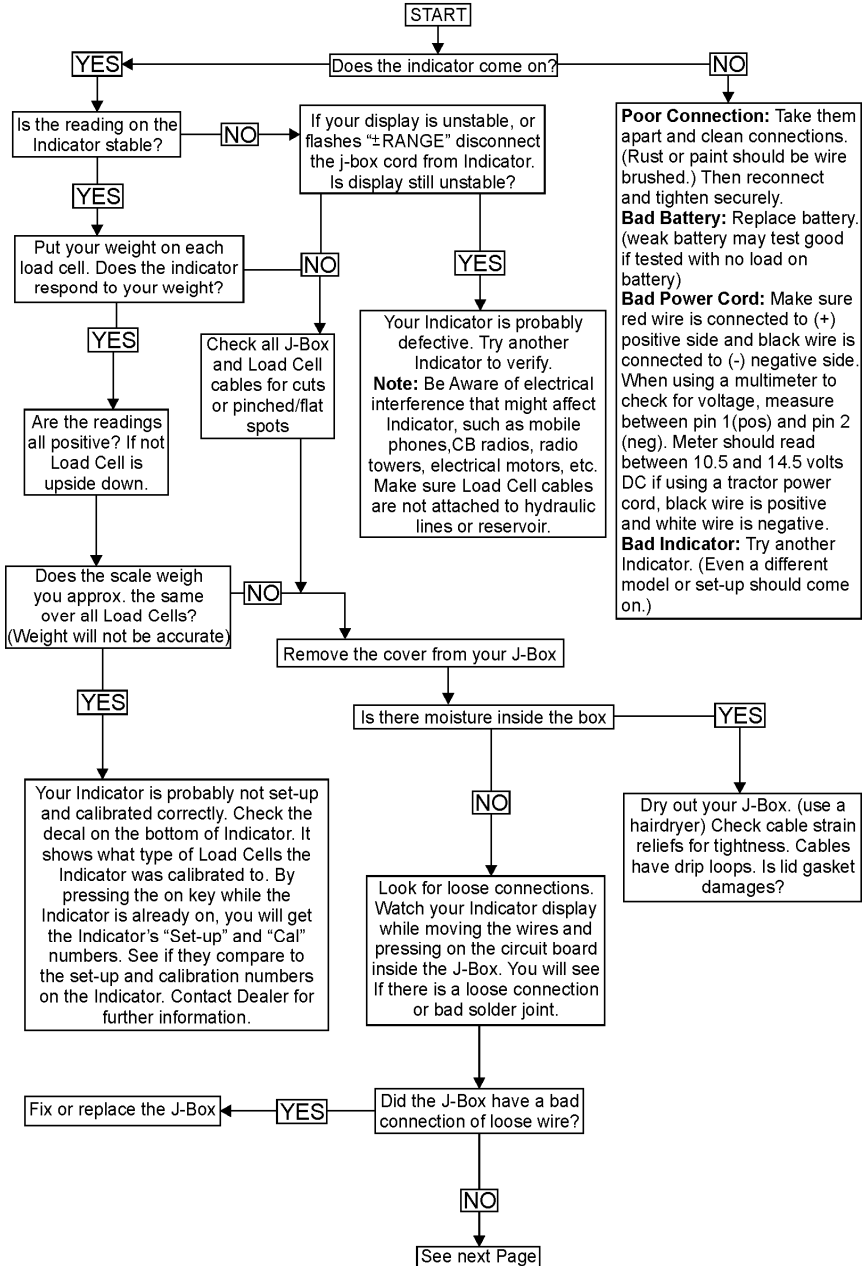

FLOW CHART

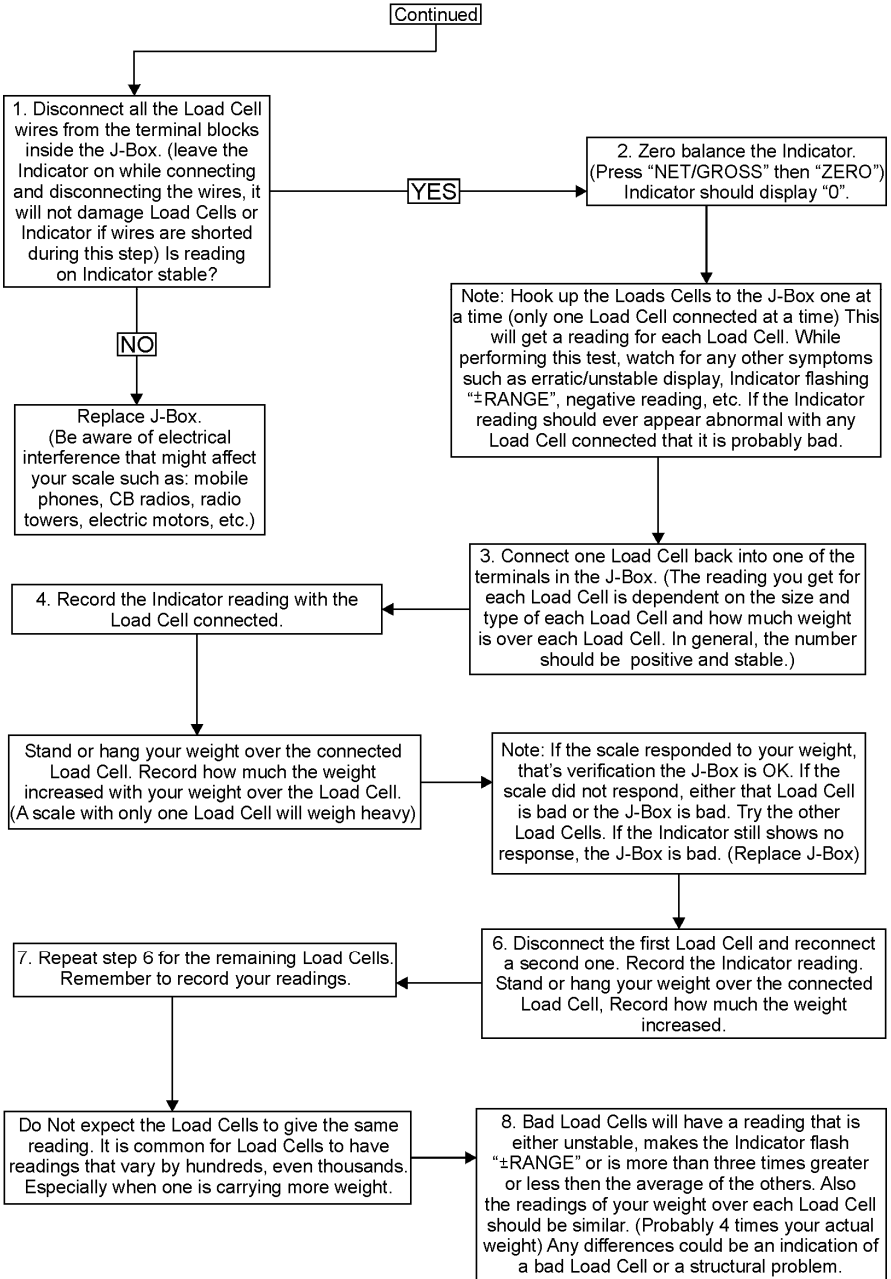

INSTALLATION

Indicator Mounting

Rail Mounting
Included

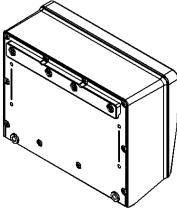

Wing Mount
Included

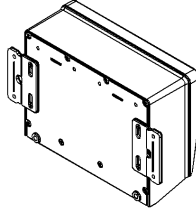

RAM Mount
Optional

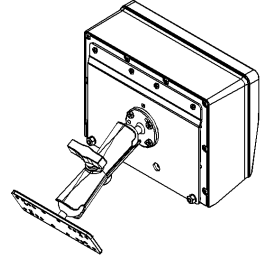

Indicator Mounting

Rail Mount (Standard) and Wing Mount w/ hardware included.
RAM Mount Optional Kit, hardware included w/ kit.

Load Cell Direction

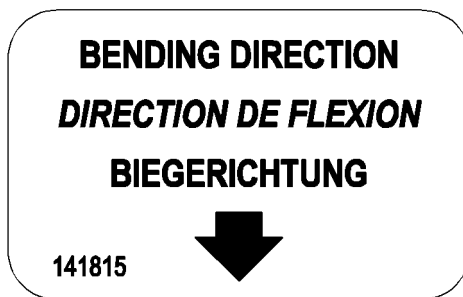

Observe direction of arrow when installing load cell.

Cable Connection

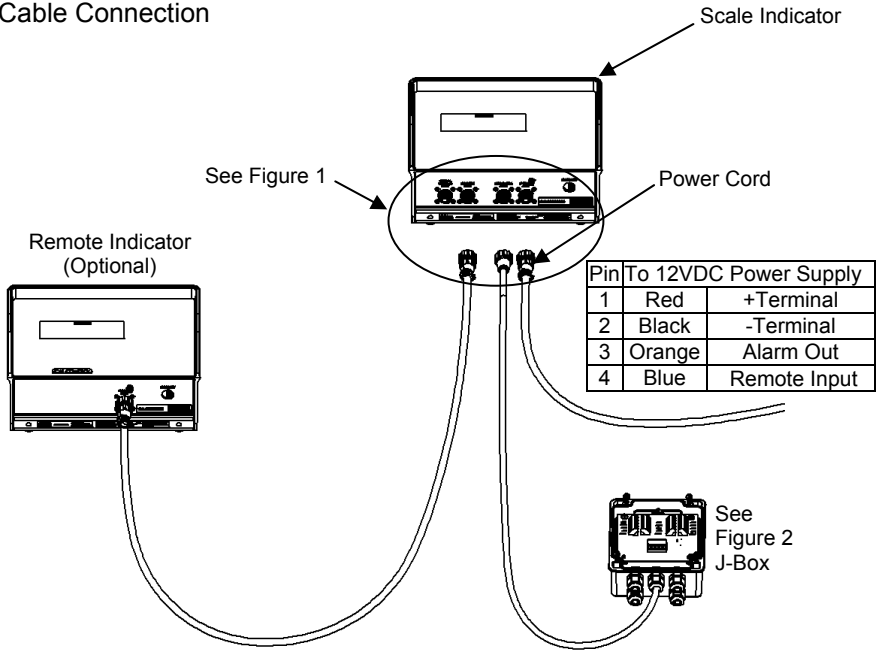

Indicator Connection Diagram

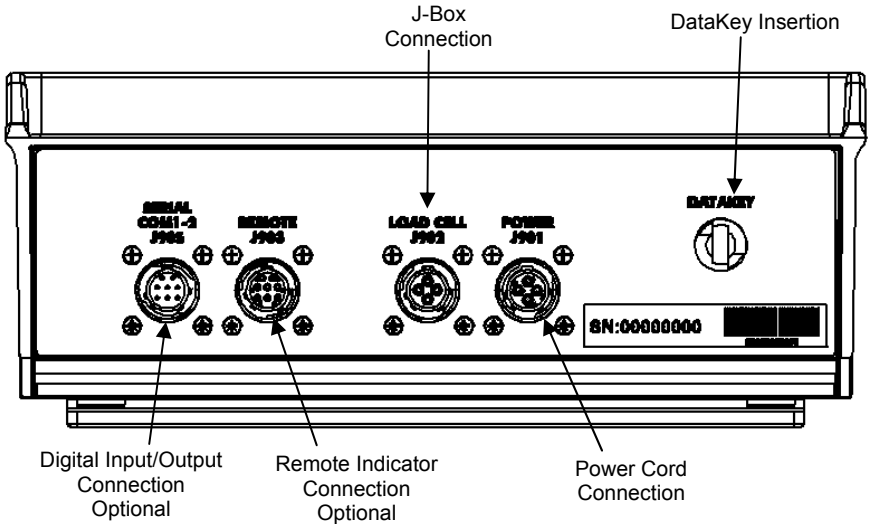

Figure 1 Bottom Panel Cable Connections

Connect Load Cells To J-Box

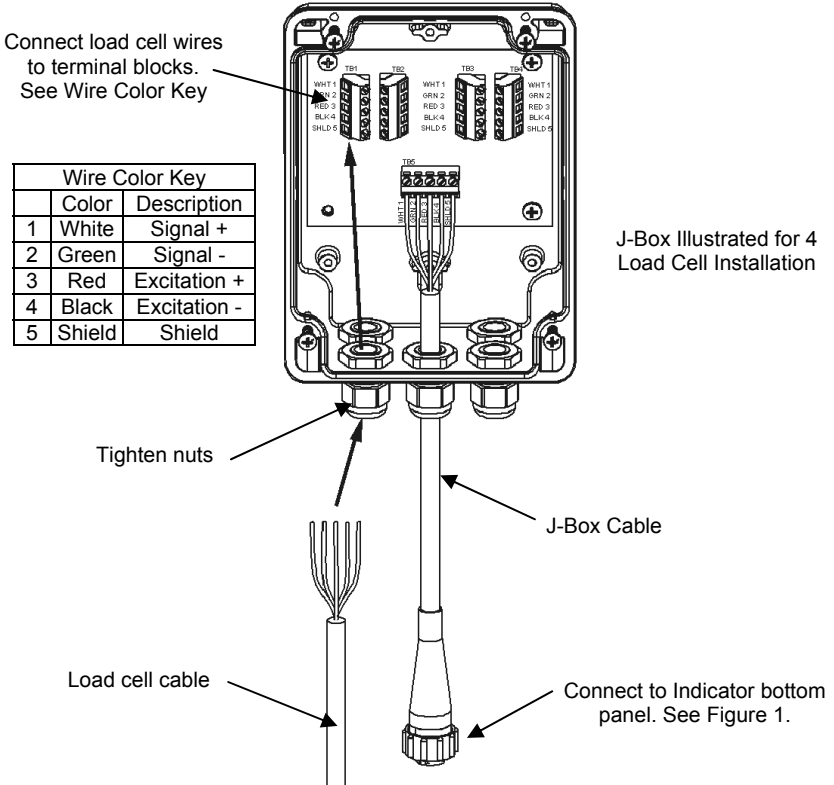
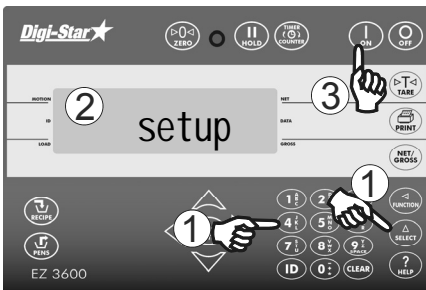

Figure 2 J-Box Connections

Change setup and calibration numbers



1. Enter **871** and press .
2. Indicator shows **SETUP** briefly then shows a 6 digit number. Enter new number.
3. Press .

Follow same procedure changes calibration number except use **872**.

OPTIONAL EQUIPMENT

Rotation Counter Sensor

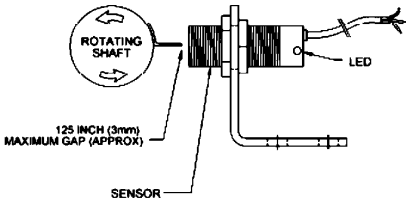

Use with EZ3600 or EZ4600 indicators equipped with rotation counter port. Sensor allows operator to program indicator to count auger or PTO rotations for accurate mix.

Transmitter/Receiver



Transmitter (shown) with factor installed receiver in indicator. Use to zero indicator from remote location. Operating range about 90 feet.

Remote Indicators



RD440 small remote display with 1" high numbers

RD2400V backlit remote display with 1.7" high numbers

RD4000 LED remote display with 4" high numbers