

Digi-Star★

EZ4600 Operators Manual

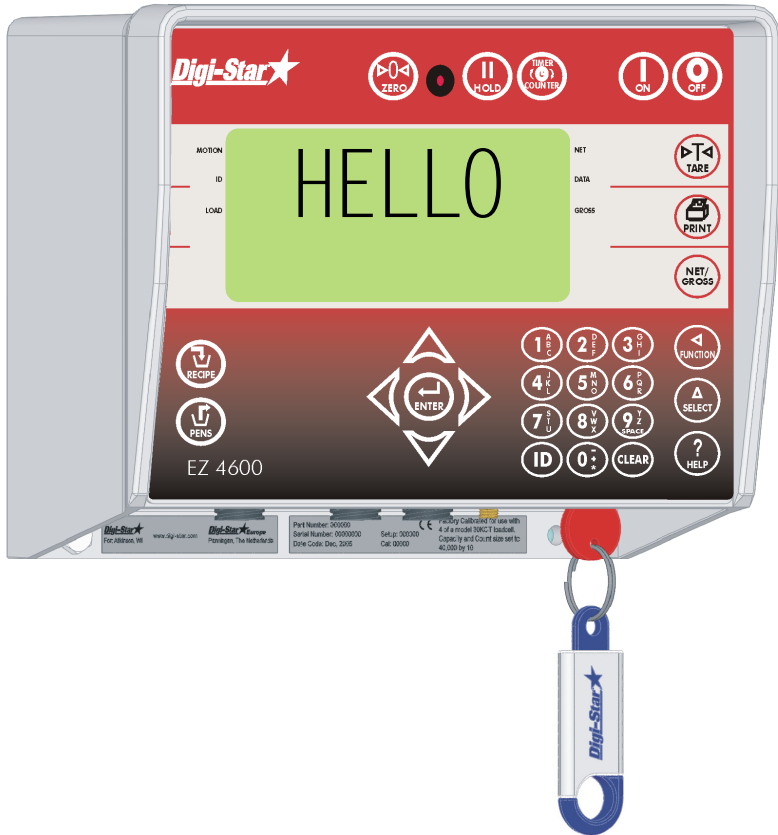

Digi-Star★

Ft. Atkinson, Wisconsin USA

Digi-Star★Europe

Panningen, The Netherlands

www.digi-star.com

Table of Contents

FEED MANAGEMENT SOFTWARE.....	4
CAB CONTROL (WIRELESS).....	5
BEFORE CHARGING BATTERY OR WELDING	6
INDICATOR OVERVIEW.....	7
OPERATION.....	9
TURN ON INDICATOR.....	9
DATA TRANSFER.....	10
DATAKEY MODE.....	10
RF DATALINK MODES	10
INDICATOR DATA FORMATS	11
LOADING AND FEEDING.....	11
COMPLETE LOADS MODE.....	11
STARTING A RECIPE	11
RESIZE RECIPE WEIGHT	12
LOADING RECIPE.....	13
UNLOADING TO PENS.....	14
RECIPE AND PEN LIST MODE.....	15
STARTING A RECIPE	15
LOADING RECIPE.....	16
UNLOADING PENS.....	16
ADVANCED COMMANDS	17
UNLOAD PARTIAL PENS	17
GO BACK TO SKIPPED INGREDIENT.....	17
CHANGE FEEDING NUMBER.....	18
USE ARROW KEYS RECIPE OR PENS LIST.....	18
CLEAR INDICATOR MEMORY	19
RE-USE RECIPE AND PEN DATA	19
ADD A PEN TO PEN LIST.....	20
HOLD	21
PRINTING.....	21
BACKLIGHT INTENSITY	21
COMMONLY USED DIRECT ACCESS NUMBERS	22
PRE-ALARM	22
AUTO INGREDIENT / MANUAL PEN ADVANCE.....	22
AUTO ADVANCE.....	23
TOLERANCE	23
PEN TOLERANCE.....	23
DELAY TIME.....	23
DRIVE RATIO	24
SCALE ID OR TRUCK ID	24
RADIO NUMBER	25
RESIZE OPTION	25
CHANGE TIME	26
CHANGE DATE	26

DIRECT ACCESS NUMBERS LIST 27

 MENU 1. BASIC FEATURES IN MOST INDICATORS 27

 MENU 2. CLOCK, PRINTER, COMMUNICATIONS & ESTIMATED
 WEIGHT FEATURES 27

 MENU 3. SCALE CALIBRATION SETTINGS 28

 MENU 4. PRESET. BATCHING & ROTATION COUNTER FEATURES . 28

 CALIBRATION 29

TROUBLESHOOTING 30

INSTALLATION 32

 INDICATOR MOUNTING 32

 LOAD CELL DIRECTION 32

 CABLE CONNECTION 33

 CONNECT LOAD CELLS TO J-BOX 34

 CHANGE SETUP AND CALIBRATION NUMBERS 34

OPTIONAL EQUIPMENT 35

 ROTATION COUNTER SENSOR 35

 TRANSMITTER/RECEIVER 35

 REMOTE INDICATORS 35

FEED MANAGEMENT SOFTWARE



A full featured Windows[®] based system that offers powerful features that are easy to use.



Entry level system easily upgraded.
Based on features of TMR Tracker



Remote site monitoring software.
Works with email service to connect
Tracker to remote location



Front-end tool for beef feeding customers
to enter ingredient, recipe, corral and
wagon information.

CAB CONTROL (WIRELESS)



Features

- Wireless remote with full key control of indicator on mixer
- Mount remote in easy view of loading
- Improves loading accuracy

Functions

- Communicates with multiple mixers
- Easily call-up recipes without leaving loader

Specification

- Internally mounted 2.4 GHz radios
- Up to 1000 foot range
- 24 channels
- 12 or 24 volt DC system

For additional information go to www.digi-star.com

BEFORE CHARGING BATTERY OR WELDING

Important Precaution

**Disconnect all indicator leads before charging battery or welding.
Damage may occur to indicator and load cells.**

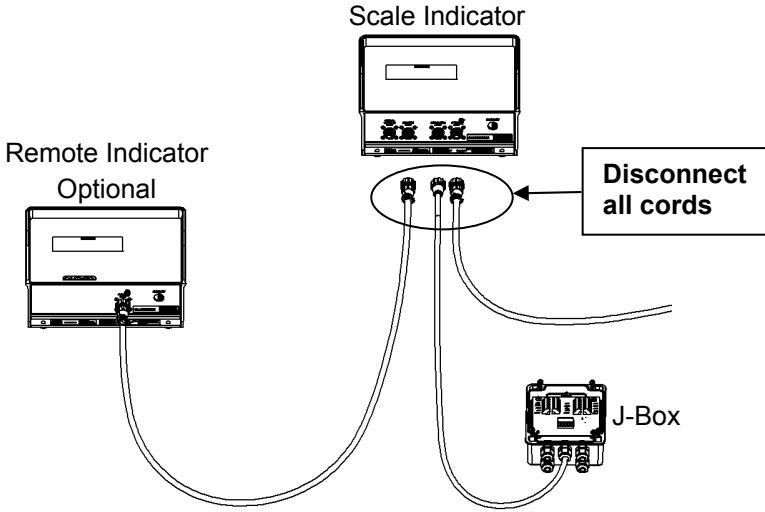



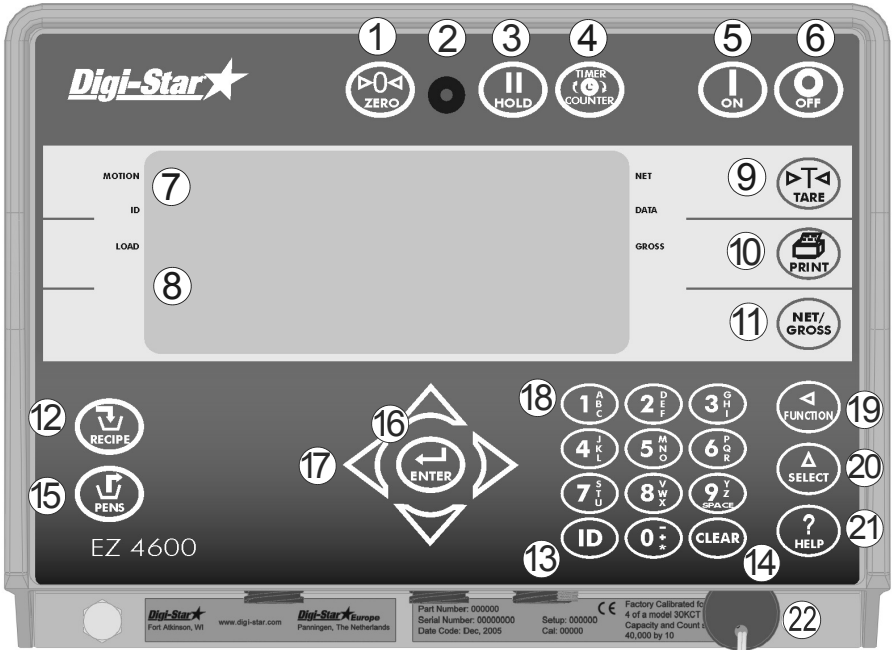







INDICATOR OVERVIEW



Note: See page 32-34 for installation instructions



- ① -press and hold for 3 seconds to zero balance indicator.
- ② Pre-Alarm Light – Flashes and alarm sounds when weight is within preset limit. See page 22
- ③ – holds displayed weight when moving machine.
- ④ – not used.
- ⑤ - turns indicator on, press quickly 2 times to run self test.
- ⑥ - turns indicator off.
- ⑦ Upper Display Window – Displays current actions.
- ⑧ Lower Display Window – Lists 3 lines (i.e. ingredients, recipes, pens).

- 9  - temporary zero (Net Mode).
- 10  - records to memory or prints displayed weight.
- 11  - toggles between Net and Gross weights.
- 12  - selects recipes in memory.
- 13  - enter user number and feeding number. Any number can be used for user until number assigned by management software.
- 14  - Clear (backspace).
- 15  - press in List Mode to begin pen unloading. See page 16
- 16  - accepts change or proceeds to next item.
- 17 Directional Arrows - moves through list of information.
- 18 Keypad - inputs numbers or letters as required.
- 19  - performs the task displayed by select.
- 20  - displays additional tasks.
- 21  - press for additional information.
- 22 DataKey - Used for data transfer between computer and indicator.

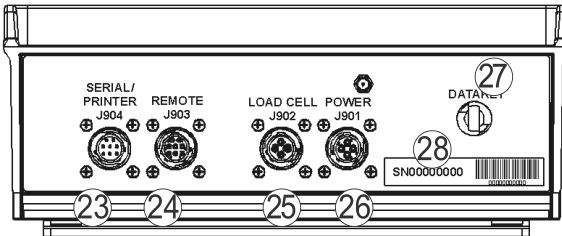

- 23 Serial/Printer Port - optional, to communicate with computer and other digital input/output devices.
- 24 Remote Port - optional, for remote display.
- 25 Load Cell Port- for J-Box cord.
- 26 Power Port - for power cord.
- 27 DataKey Port- for DataKey insertion. Turn DataKey to upload/download data.
- 28 Serial Number Plate - Serial Number of indicator.

OPERATION

Turn on indicator



1. Press .



1. Enter ID Number if required.
2. Press .

1. Enter Feeding Number (only req'd 1st time in loads mode).
2. Press .



1. Press and hold  for 3 seconds to zero balance indicator.

DATA TRANSFER

DataKey Mode

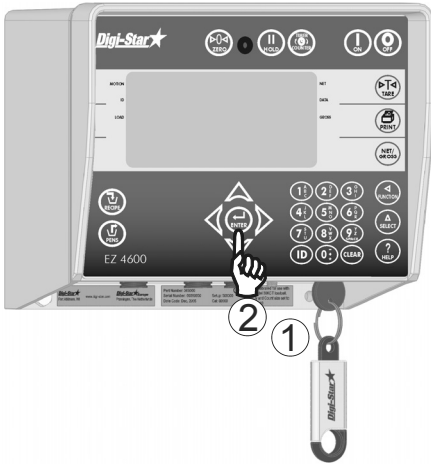

To upload data:

1. Insert DataKey turn clockwise.
2. Press .



Note: If indicator displays uncompleted data in memory, press  to overwrite uncompleted data.

Remove DataKey when transfer complete.

To download data:

Insert DataKey, turn clockwise, indicator automatically sends data to DataKey. Remove DataKey.

RF DataLink Modes

Operation	Message
DataLink connects with indicator	←PC→
DataLink sends data to indicator	DL←IN
Indicator receives data	ALL FEED LINES RECEIVED -PRESS RECIPE KEY TO CONTINUE
Data complete, indicator sends data to DataLink	←PC→
Data sending	DL→OUT
To send data to PC if operator does not complete all feeding at end of feeding schedule. Press  until display shows message (right column), press  to select	EZ→PC
The indicator marks uncompleted data as completed and sends feeding data to DataLink.	

Note: After sending, uncompleted data erased.

Indicator Data Formats

Complete Loads Mode: Each load built by PC software. It assigns pens to a recipe and builds exact load for pens.

Recipe and Pen List Mode: PC software sends recipe data and pen data in two different fields. Operator selects recipe to build and pen deliveries.

LOADING AND FEEDING COMPLETE LOADS MODE

Starting A Recipe



1. Press .



1. Indicator scrolls feeding number, first recipe and pen number. Recipes listed below.

2. Press and to find desired recipe.

3. Desired recipe in upper display line, press .

Resize Recipe Weight



Indicator gives option to resize pen load weight.

1. Enter a new weight or keep original weight.

2. Press .

Note: Press  to resize by number of head in pen.

Note: Press  to accept pen values without resizing.

Note: If indicator warns resized amount is over capacity, press  to override.

Loading Recipe



1. First ingredient weight flashes in upper display, load ingredient.
2. Weight approaches zero, alarm will flash and sound.
3. a. Manual Advance: Weight reached, press to accept. Press again to start next ingredient.
- or
3. b. Auto Advance: When preset weight reached, indicator advances to next ingredient.

Displayed when in load or unload mode.

Line 1:

feeding number: FD-2
 number of rotations during pen delivery: CTR-000 (RC option only)
 pen name: PEN-1

Line 2:

zone number: ZN-1
 name of recipe: REC-PREFRE
 call weight of pen: PRE-1200



Line 3:

gross weight: G-10000
 Instruction data: USE ADVNCE TO LOG

Unloading to Pens



Ingredients loaded, indicator displays first pen to unload.



1. Manually advancing, press  for 1st pen. When weight reached press  to accept. Press  again to start next pen.

or

1. b. Auto Advance: When preset weight reached, indicator advances to next pen.

Note: Do not press .

Note:

If different pen needed press  or  to find desired pen.

Press  for pen delivery.

Last pen complete, indicator displays: "Recipe Complete"

RECIPE AND PEN LIST MODE

Starting a Recipe

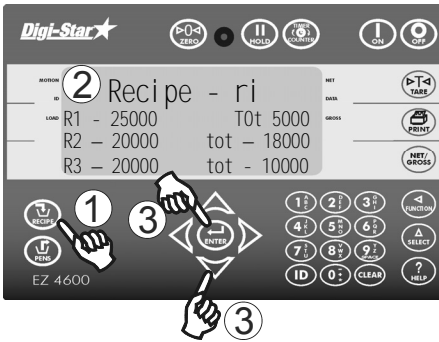

1. Press .
2. Display reads:

Example:

Line 1: Recipe R1
 Line 2: R1 - 25000 TOT- 50000
 Line 3: R2 - 20000 TOT-18000
 Line 4: R3 - 20000 TOT- 10000

3. Press and to select recipe, to start.

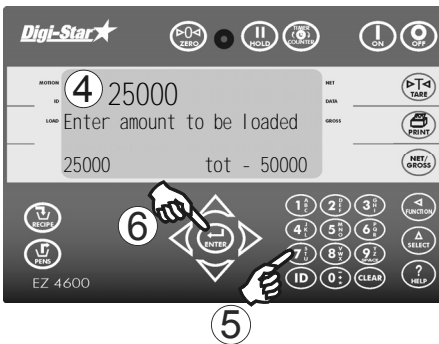

Indicator will display: RESI ZE, then the resize weight.

4. Display reads:



Example:

Line 1: 25000
 Line 2: Enter load amount
 Line 3: (No Data)
 Line 4: R1 - 25000 TOT- 50000

5. Enter the amount to build in this load.
6. Press .

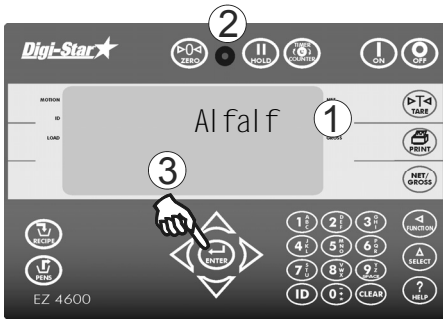





Loading Recipe

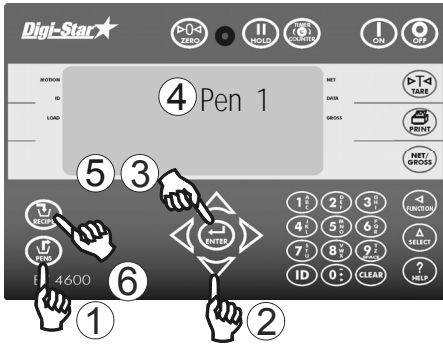

1. First ingredient and weight flash in upper display. Begin loading ingredient.
2. Weight reached, alarm will flash and sound.
3. a. Manual Advance: Weight reached, press . Press  to start next ingredient.
- or
3. b. Auto Advance: When preset weight reached, indicator advances to next ingredient.

Unloading Pens



1. When ingredient loading complete, display reads "Recipe Complete". Press . Indicator displays unloading pens.
2. Press  or  to select desired pen.
3. Press .
4. Pen and weight displayed, begin unloading to pen.
5. a. Manual Advance: Weight reached, press  to accept. Press  again to start next pen.
- or
5. b. Auto Advance: When preset weight reached, indicator advances to next pen.
6. When unloading is complete press  to start next recipe.

ADVANCED COMMANDS

Unload Partial Pens

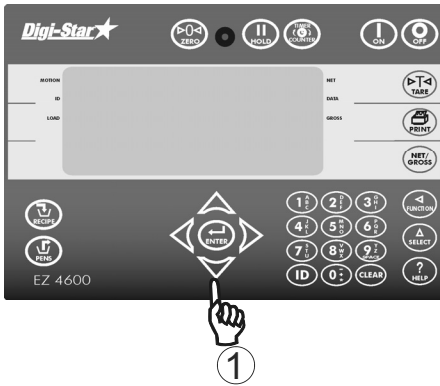

1. Press  to advance to next pen without finishing current pen.



Note: If pen tolerance is set and feeding stopped before preset weight reached, alarm sounds, indicator displays:

Pen Underfed – Press Print
To remove pen from list
Press on to keep pen

See page 23 for Pen Tolerance set-up.

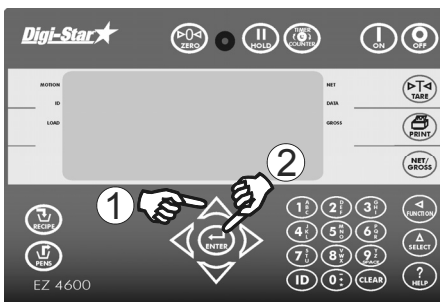
Go Back To Skipped Ingredient



1. Press  or  to move back.
2. Press .

Note: Ingredient weight changed more than 4 display counts cannot restart that ingredient.

Example: If minimum display change is 10 lbs/kgs, more than 40 lbs/kgs, cannot restart that ingredient.

Change Feeding Number

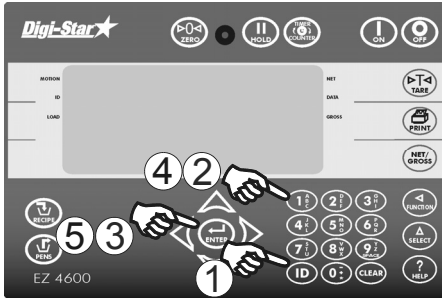

1. Press **ID**.
2. Enter user number.
3. Press **ENTER**.
4. Enter feeding number (1-9).
5. Press **ENTER**.

Use Arrow Keys Recipe or Pens List

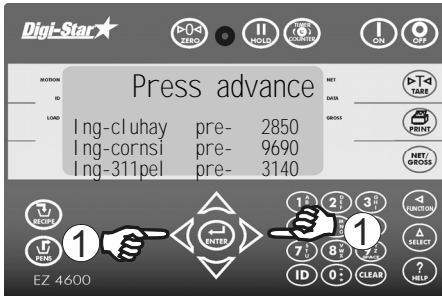

1. Press **◀** or **▶** to move list three lines at a time.

Clear Indicator Memory



1. Press **OFF**.
2. Press and hold **CLEAR**.
3. Press **ON** continue holding **CLEAR** indicator reads:
On=Clear Clear=Reuse Net=exit.
4. Press **ON** to erase feeding memory.

Re-Use Recipe and Pen Data

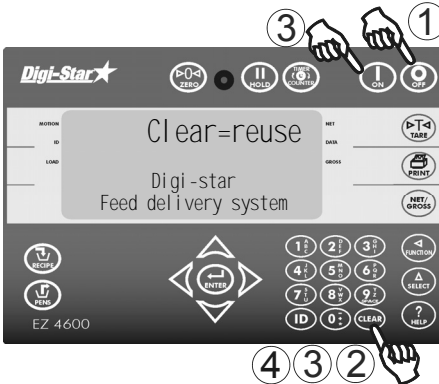



1. Indicator **OFF**.
2. Press and hold **CLEAR**.
3. Press **ON** continue holding **CLEAR** indicator scrolls:
On=Clear Clear=Reuse Net=exit.
4. Press **CLEAR** again to re-use recipe and pen data.

Note: When re-using data stored in indicator, it takes recipe and pen information and removes completed weights loaded or unloaded and marks them undone. It will not accumulate data day to day. Download data to DataKey before re-using recipe and pen data stored.

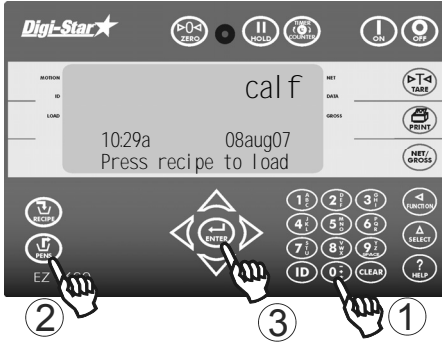

Note: For continuous re-use, set D.A.N. **466** to on. See page 29.

Add a Pen to Pen List





1. Enter pen name or number.
2. Press .
3. Press .

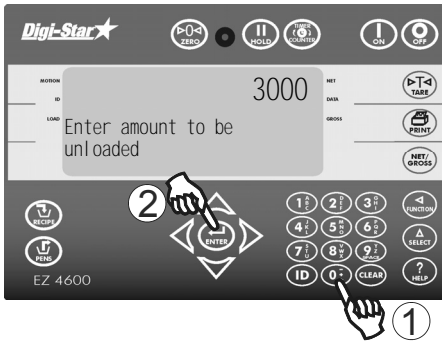

1. Press  or  to find desired recipe.
2. Press .



1. Enter amount to unload to pen.
 2. Press .
1. Enter number of animals / pen.
 2. Press .



1. If zones are active display reads: "Enter Zone 0-9"
2. Press .

Hold

Hold mode prevents displayed weight from changing while moving.



1. Press .
2. Press indicator normal.

If weight added in hold mode, press to cancel hold.

PRINTING



1. Reference technical manual D3648 at www.digi-star.com.

Backlight Intensity

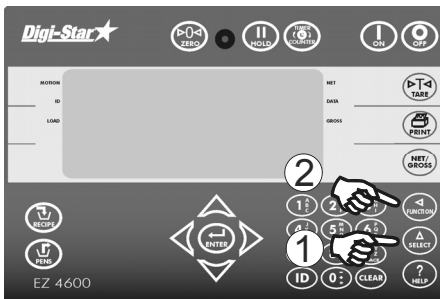





1. Press until dimmer is displayed.
 2. Press to reduce backlight intensity by 60%.
- Press again for full intensity.

COMMONLY USED DIRECT ACCESS NUMBERS

Pre-Alarm

Select weight or percentage method, enter value to activate early warning indicator reaching preset.





1. Enter **401** and press .
2. Press  again to change between WEIGHT and PERCENT.
3. Press .
4. Enter Pre-Alarm value. Press .

Auto Ingredient / Manual Pen Advance

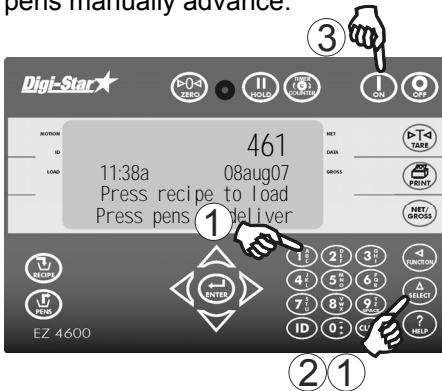
Ingredients automatically advance pens manually advance.



1. Enter **461** and press .
2. Press , choose on/off.
3. Press .

Auto Advance

Allows hands free operation of programmed recipes. When auto advance feature activated, indicator automatically advances to next ingredient once tolerance, and delay time requirements met.

Tolerance



1. Enter **442** and press . Press again to choose desired percentage. Percentage settings:
OFF, 0.5, 1 - 5, 7, or 10.
2. Press .

Pen Tolerance

Available in List Mode Only.

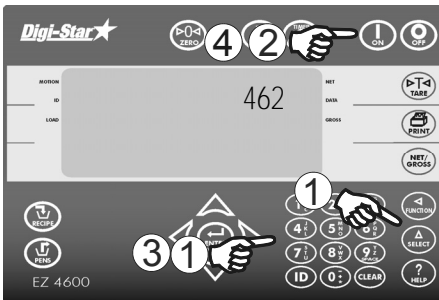

1. Enter **462** and press . Press again to choose weight or percent.
2. Press , screen will display "pentol".
3. Enter weight or percentage desired.
4. Press .

Delay Time

Changes time indicator waits before automatically advancing to next ingredient.





1. Enter **443** and press . Press again to select delay time (In seconds: Manual, 1, 2, 3, 5, 7, 10, 20, 30, or 60).
 2. Press .
- Note:** Set to Manual prevents automatic advance.

Drive Ratio

Drive ratio is number of turns seen by sensor divided by number of mixing rotations.



1. Enter **422** and press  to enter drive ratio value.

2. Press .

Scale ID or Truck ID

Each indicator has scale ID.



1. Enter **108** and press .



2. Press  to erase old ID, enter new ID.

3. Press .

Note: TMR Tracker or Diet Manager, software ID must match.

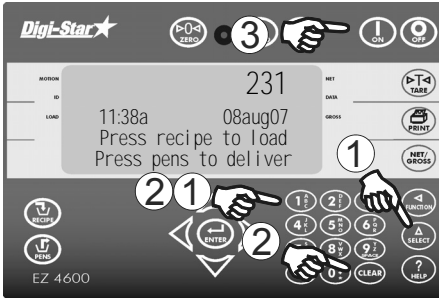
Radio Number





1. Enter **231** and press .
2. Press  to erase number, enter new number.
3. Press .

Note: Do not use same number for two different indicators.

Resize Option





Make weight change to pen unload weight or recipe load size.

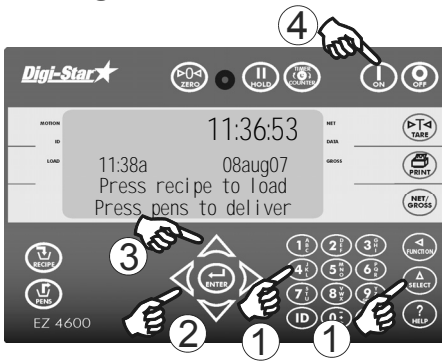

1. Enter **448** and press , press  again choose on/off.
2. Press .





Change Time

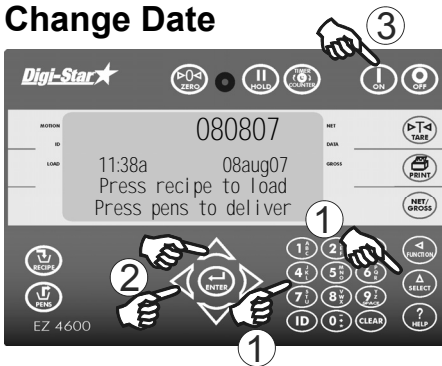

1. Enter **202** and press .
2. Press  to move cursor.
3. Press  sets time.
4. Press .

Change Date



1. Enter **204** and press .
2. Press  to move cursor. Format ddmmyy,  set date.
3. Press .

DIRECT ACCESS NUMBERS LIST

Enter D.A.N. press  displays setting name, allows value change.

Press  to save setting.

SETTING/ DISPLAY	D.A.N NO.	OPTIONS (BOLD=DEFAULT)	DESCRIPTION
MENU 1. BASIC FEATURES IN MOST INDICATORS			
LANGUAGE {langag}	101	English(ENGLISH) (NEDERL) French (FRANCS) Dutch(DEUTSH) Italian (ITAL) Portuguese (PORT) Spanish (ESPAN) Danish (DANSK) (MAGYAR) (VESTA)	Select language to be displayed.
TR HOLD {tr hld}	107	ON/OFF	Display gross weight if TR key is held for 3 seconds.
SCALE ID SETUP {scal id}	108	NEW EZ	Identity of scale location (truck id or Mixer number).
MENU 2. CLOCK, PRINTER, COMMUNICATIONS & ESTIMATED WEIGHT FEATURES			
TIME FORMAT {time f}	201	24 HR AM/PM	Select time format -AM/PM or 24 hour
1 TIME {time}	202	XX:XX:XX	Select key changes time, function key chooses hh:mm:ss.
DATE FORMAT {date f}	203	1-mm-dd 2-mm/dd/yy 3-mm/dd/yyyy 4-dd-mm 5-dd/mm/yy 6-dd/mm/yyyy 7-ddmoyy 8-ddmoyyyy.	Select date format
DATE {date}	204	Enter XXXXXX	Select key changes date - function key chooses mm/dd/yy .
SCALE NUMBER SCL NO	231		Select scale number for cab control communication

SETTING/ DISPLAY	D.A.N NO.	OPTIONS (BOLD=DEFAULT)	DESCRIPTION
REMOTE DISPLAY RMDI SP	234		Select type of remote display
MENU 3. SCALE CALIBRATION SETTINGS			
DISPLAY UNIT {lb-kg}	303	LB/KG	Display pounds -lb or kilograms - kg
MIMIC TYREL {tc1300}	321	OFF/ON	If ON -records preset weights like a TYREL TCX-1300 indicator. Indicator Tracks gross weight while batching.
MENU 4. PRESET. BATCHING & ROTATION COUNTER FEATURES			
PRE ALARM {p mthd} & {p-alm} ..	401	WEIGHT PERCNT	Select weight or percentage method, then enter a value to activate an early warning that indicator is reaching the preset.
BUZZER {buzzer}	404	1-4, ON/OFF	ALARM BUZZER -allows user to turn off alarm horn.
TIMER/ COUNTER {tmrctr}	421	REV TIME	Select time or mixer revolutions to decrement mix timer/counter.
DRIVE RATIO {dratio}	422	0001.00	Enter the number of input pulses that equal 1 mixer revolution.
ENTRY METHOD E MTHD	441	1,2,3	Select batch 1-amount/animal 2-percent/load 3- amount/load
TOLERANCE {toler}	442	OFF, .5,1-5,7,10	Select tolerance weight percentage to accept ingredient.
INGR. ADVANCE DELAY {del ay}	443	MANUAL, 1- 3,5,7, 10,20,30,60	Select seconds to delay before advancing to next ingredient.
FORCE USER ID {user i d}	446	ON/OFF	If ON -operator must enter user ID to use indicator.
RESIZE RECIPE {resi ze}	448	ON/OFF	If ON -operator can change recipe size.
TOLER OVER LOCK {overl k}	453	ON/OFF	If ON -prevents auto-advancing if preset exceeds tolerance
FEED ZONE {fdzone}	454	ALL, 1-9	Select feed zone for recipe deliveries.
UNDONE RECIPES {undn 1}	455	ON/OFF	If ON -displays all incomplete recipes or enable if indicator is stationary mixer/batch when using Datalink.

SETTING/ DISPLAY	D.A.N NO.	OPTIONS (BOLD=DEFAULT)	DESCRIPTION
AUTO START PENS {autpen}	458	ON/OFF	If ON -starts pens list after recipe is loaded in list mode format.
MANUAL PEN ADVANCE {manpen}	461	ON/OFF	If ON -overrides automatic advance for pens.
PEN TOL {t_mthd} & {pentol}	462	WEIGHT PERCNT	Select weight or percentage method, then enter pen tolerance.
PEN WEIGHT {pen wt}	463	LOAD GROSS NET	Select method for displaying pen Weight -net, load, or gross.
DOUBLE KEY PRESS PREV {dbkey}	465	ON/OFF	Select method ignores double pressing of keys when advancing ingr. While loading mixer.
RECIPE REMAIN ACTIVE {RE-USE}	466	ON/OFF	Select ON to reuse recipes.
CALIBRATION			
SETUP NUMBER SETUP	871		Quick entry method selects weigh method 1-4lbs, 5-8 kg, gain 1-9, display counts 1-9 and capacity *1000
CALIBRATION NUMBER CAL	872		Weight displayed at 0.4mV/V for these load cells

TROUBLESHOOTING

FLOW CHART

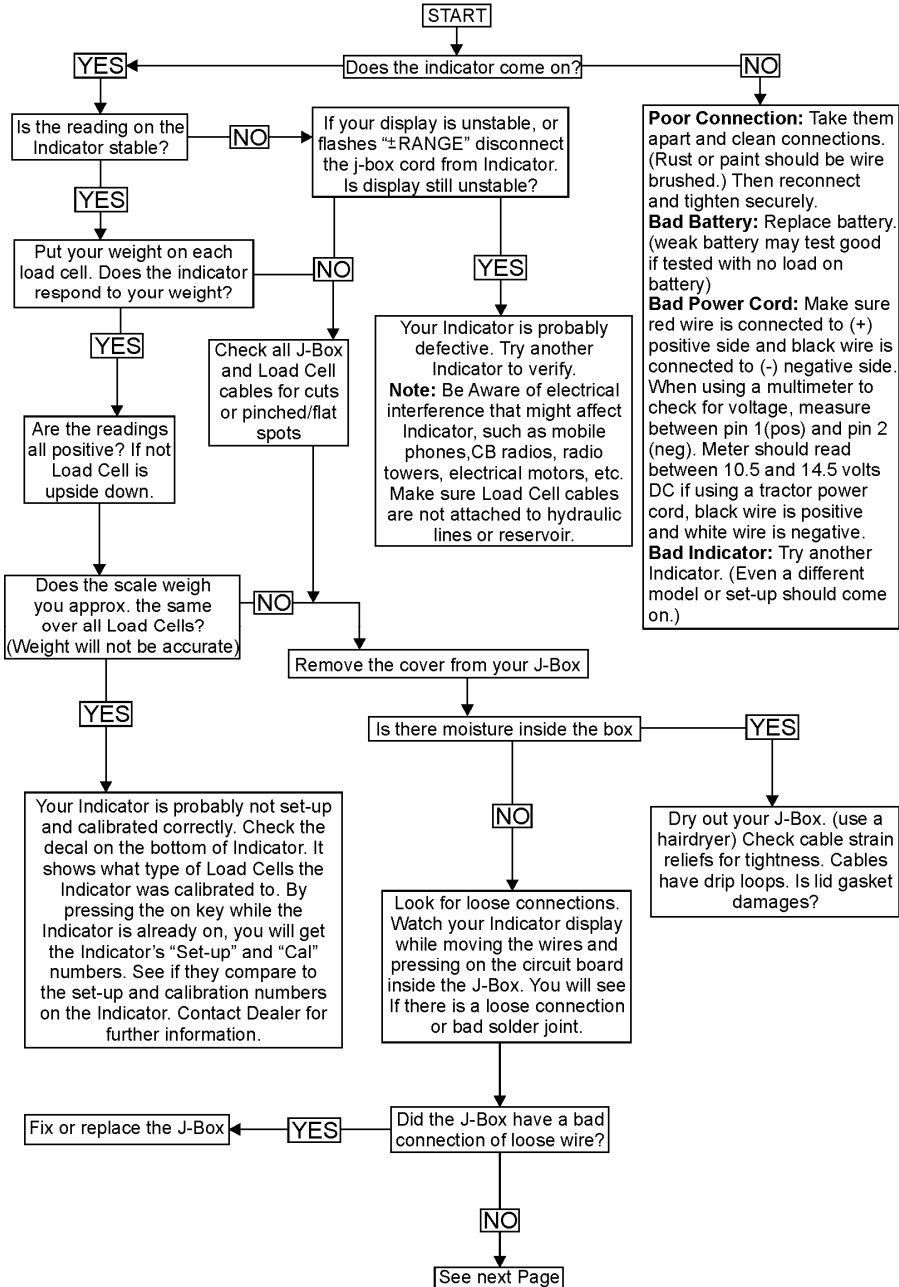

FLOW CHART

Continued

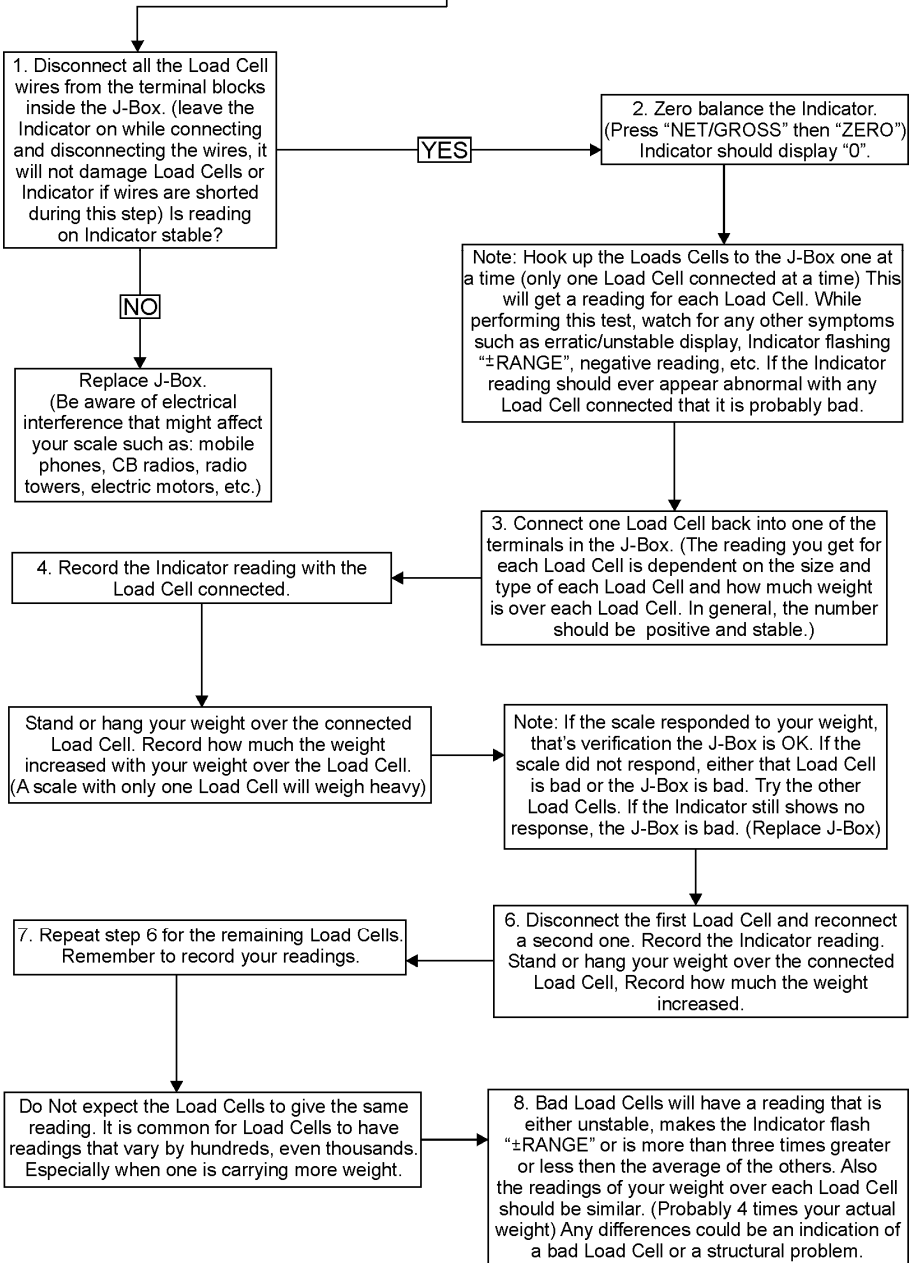

INSTALLATION

Indicator Mounting

Rail Mounting
Included

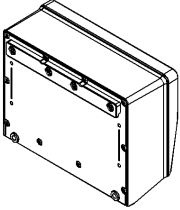

Wing Mount
Optional

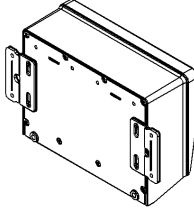

RAM Mount
Optional

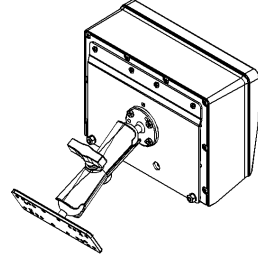

Rail Mount (Standard), Wing Mount w/ hardware, RAM Mount Kit w/ hardware kit.

Load Cell Direction



Observe direction of arrow on load cell when installing load cell.

Cable Connection

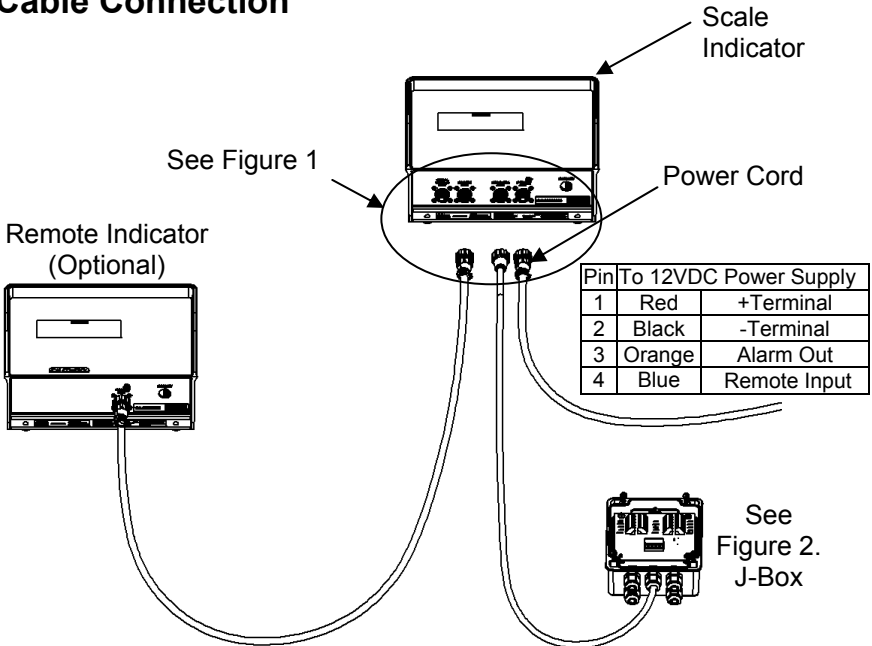

Indicator Connection Diagram

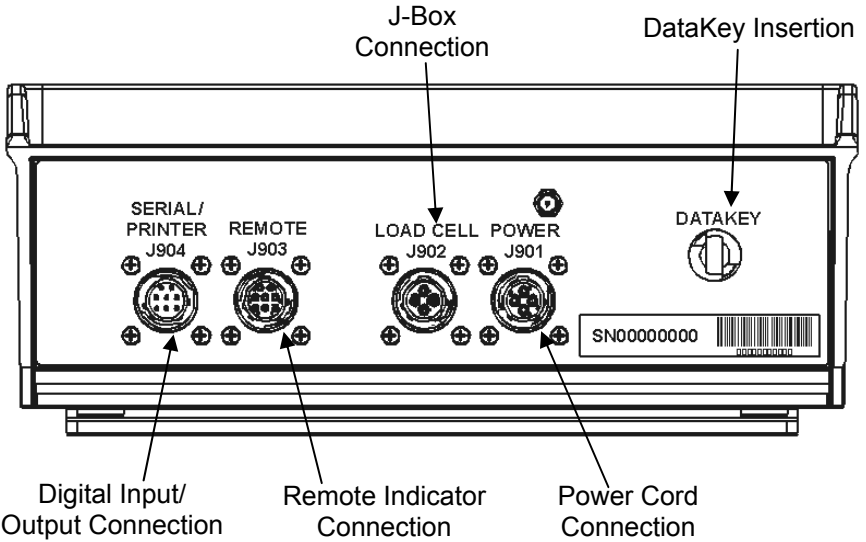

Figure 1. Bottom Panel Cable Connections

Connect Load Cells To J-Box

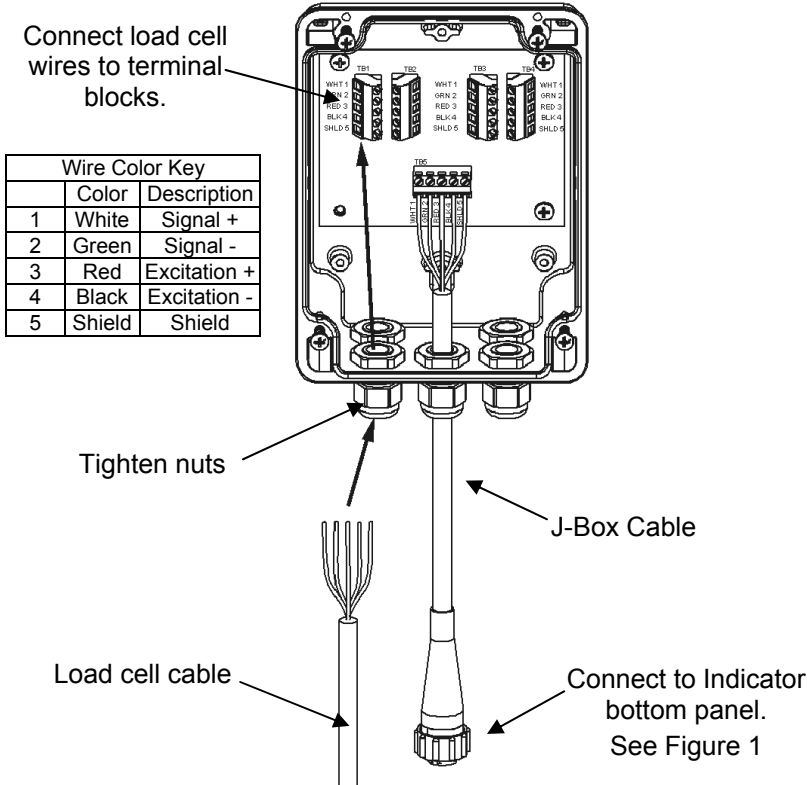

Figure 2. J-Box Connections

Change Setup and Calibration Numbers



1. Enter **871** and press **SELECT**.
2. Indicator shows **SETUP** briefly then show a 6 digit number. Enter new number.
3. Press **ON**.

Follow same procedure changes calibration number except use **872**.

OPTIONAL EQUIPMENT

Rotation Counter Sensor

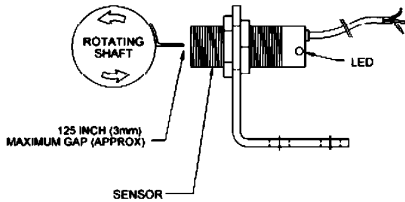

Use with EZ3600 or EZ4600 indicators equipped with rotation counter port. Sensor allows operator to program indicator to count auger or PTO rotations for accurate mix.

Transmitter/Receiver



Transmitter (shown) with factory installed receiver in indicator. Use to zero indicator from remote location. Operating range about 90 feet.

Remote Indicators



RD440 small remote display with 1" high numbers

RD2400V backlit remote display with 1.7" high numbers

RD4000 LED remote display with 4" high numbers