



# Stock Weigh 300

## Operators Manual



Ft. Atkinson, Wisconsin USA



Panningen, The Netherlands

[www.digi-star.com](http://www.digi-star.com)



---

# TABLE OF CONTENTS

TECHNICAL SPECIFICATIONS .....	1
SAFETY DURING USE .....	2
Cleaning .....	2
Batteries .....	2
INDICATOR OVERVIEW .....	4
Bottom Panel .....	5
OPERATION .....	8
Turn on Indicator .....	8
Zero Balance Indicator .....	8
Weighing Animals .....	8
Turning Off the Indicator .....	8
OPTIONAL SETTINGS .....	9
Load Cell Setup .....	9
OTHER FUNCTIONS .....	10
Backlight Settings .....	10
Change the Backlight Setting .....	10
WEIGH METHODS .....	11
WEIGHING ERRORS .....	12
RUN SELF TEST .....	12
MENUS AND CALIBRATION .....	13
Calibrating Scale Using Known Weights .....	15
INSTALLATION .....	16
Indicator Mounting .....	16
Optional Ram Mounting .....	16
TROUBLESHOOTING .....	17

All rights reserved. Reproduction of any part of this manual in any form whatsoever without Digi-Star's express written permission is forbidden. The contents of this manual are subject to change without notice. All efforts have been made to assure the accuracy of the contents of this manual. However, should any errors be detected, Digi-Star would greatly appreciate being informed of them. The above notwithstanding, Digi-Star can assume no responsibility for errors in this manual or their consequence.

© Copyright! 2009 Digi-Star, Fort Atkinson (U.S.A.).



# TECHNICAL SPECIFICATIONS

**SIZE**

7.33" long x 5.25" high x 3.38" wide (186mm x 133mm x 85mm)

**WEIGHT**

2 lbs (.91 Kg)

**HELP MESSAGES**

Context sensitive help messages in 10 languages

Long messages are scrolled

**TRANSDUCER EXCITATION**

8 volts D.C. Nominal

Capable of driving eight 350 Ohms transducers

Short circuit proof

**ATC**

Auto Temperature Compensation of the internal circuitry for high accuracy weighing measurements

**TRANSDUCER SIGNAL**

Compatible with transducers having full scale indicator transfer characteristics greater than 0.25 mv/v

**"AUTO RANGE"**

(Selectable) To increase display counts at weight values of 300 and 600 display counts.

**CONNECTOR**

AMP plastic weather resistant circular connector. Gold contacts.

**POWER REQUIREMENTS**

10.5 to 16.0 V.D.C.

160 mA nominal with four 350Ω L.C.

**SET UP AND CALIBRATION**

Via front panel

**GROSS RANGE**

999,999 max.display

**LOW BATTERY WARNING**

Enabled at 10.5V nominal

**POUND/KILOGRAM**

Selectable

**DISPLAY**

STD EZ 6 Digit LCD 1.0. high

**DISPLAY RESOLUTION**

.01, .02, .05, .1, .2, .5, 1, 2, 5, 10, 20, 50, 100

**DISPLAY UPDATE RATE**

Selectable: 1, 2, 3, 4 times/sec.

**MAX. DISPLAY RESOLUTION**

Adjustable to 40,000 counts max.

**ZERO TRACKING**

Selectable, On/Off

**SPAN ACCURACY**

±(.1% + .005%/ °F) or (.1% + 0.009% °C) full scale ± 1 output count

**MOTION DETECTION**

Selectable, On/Off

**ZERO ACCURACY**

(.005%/ °F.) or (0.009% °C) full scale ±1 output count for 0.5 mv/v transducer

**ENVIRONMENTAL ENCLOSURE**

IP65, IEC 529

**WEIGH ALGORITHM**

4 internally selectable digital filters to optimize performance (General, Slow, Fast and Lock-on)

**NON-VOLATILE MEMORY**

EEPROM for balance

**OPERATING TEMP**

-29°C to 60°C

-20°F to 140°F

## SAFETY DURING USE



### Caution

### Cleaning

Do not use running water (high pressure cleaners, hoses) to clean the indicator.

### Batteries

- Use AA Batteries
- Insert batteries negative (-) end first.
- Batteries are not necessary if using an AC power adapter.

### Rechargeable Batteries

- Rechargeable batteries may be used.
- Rechargeable batteries will show a lower charge level when fully charged.
- The SW300 does not charge batteries.

### Battery Life

- Percent of remaining battery life is displayed at power-up.
- To extend battery life, select a lower backlight level or OFF. See instructions below.

### Low Battery Indication

- Low Battery message and arrow is displayed when battery low.
- Rechargeable batteries may cause low battery indication to appear earlier than necessary.

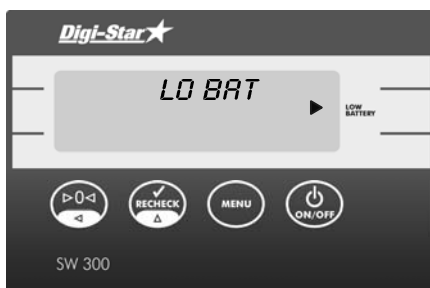



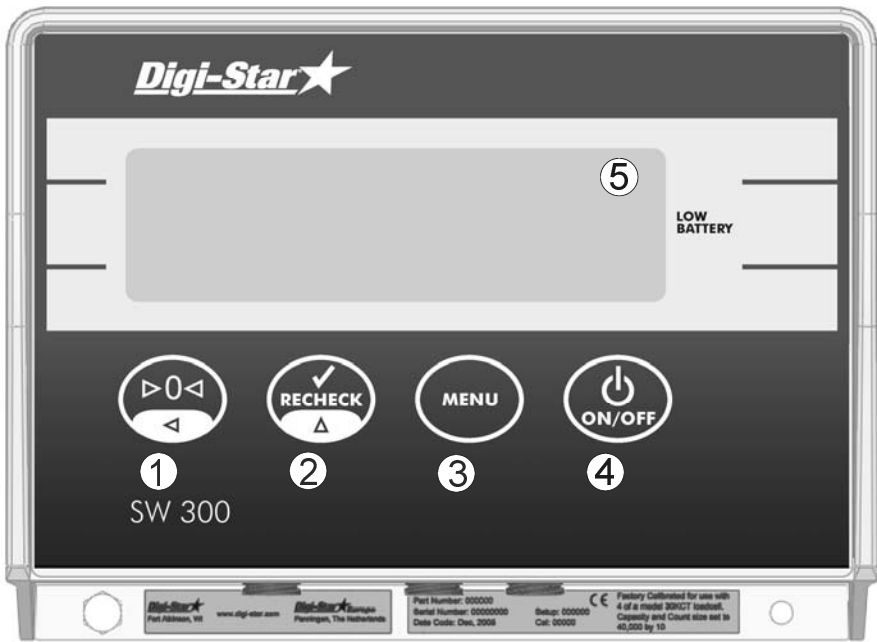

**Battery Life**

<i>BAKLIT</i>	<b>Estimated Operating Battery Life (Hours)</b>
<i>OFF</i>	40-60
<i>TIME 3</i>	30-55
<i>ON 3</i>	25-45
<i>ON 5</i>	8-16

# INDICATOR OVERVIEW



**Note:** See page 16 for installation instructions

- ①  – press and hold to zero balance.
- ②  – reweigh if scale is locked on.
- ③  – press and hold for setup menu.
- ④  – turns indicator on/off.
- ⑤ Display Window – Displays current weight or action.



## Bottom Panel

### SW300 with Load Cell Connectors

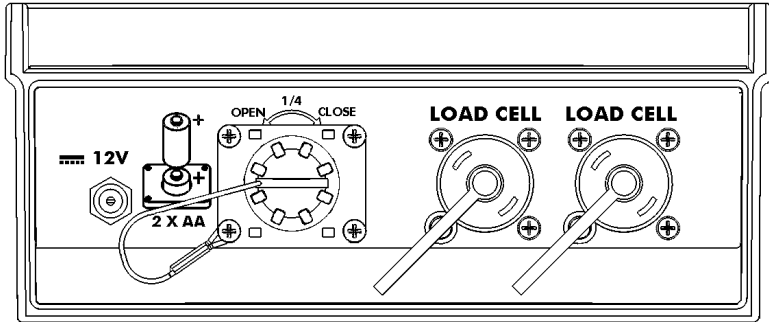

The bottom panel has a battery holder, a power connection and load cell connections.

Three different load cell connection configurations are available:

- Two load cell connectors (for use with J-Box or Load cells with connectors).
- Two liquid-tight connectors (for use with two bare-wire load cell cables)
- Two dual liquid-tight connectors (for use with up to four bare wire load cell cables)

### Power Connection

Use only the 12 Volt AC-DC converter supplied with your Stock Weigh 300.

**SW 300 W/Liquid Tight Fittings**

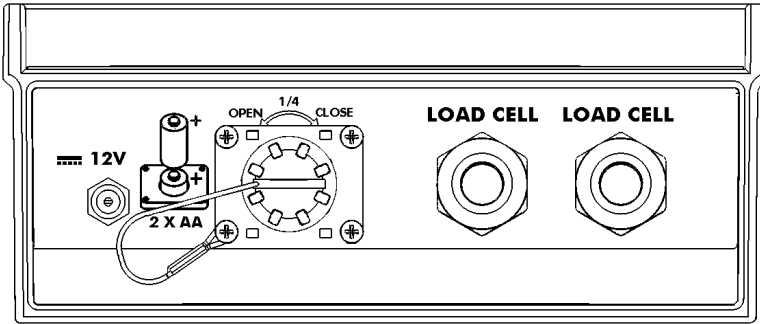

**Connecting Load Cell Wires in Indicator**

- Remove the back cover (nine screws)
- Feed the load cell wires in through the liquid-tight connectors
- Connect one wire to each terminal as shown
- Install the back cover (nine screws)

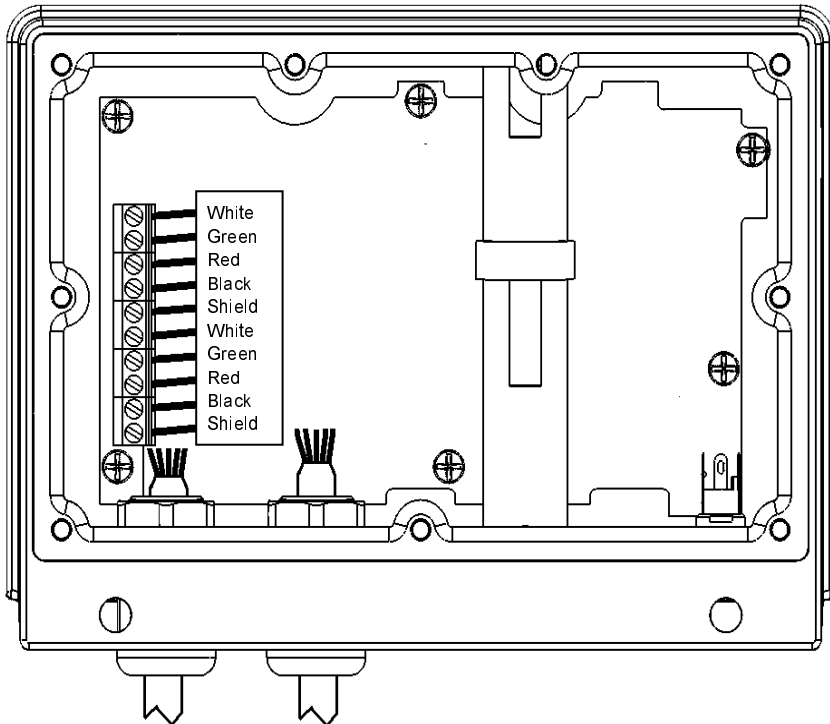

**SW300 W/Dual Liquid Tight Fittings**

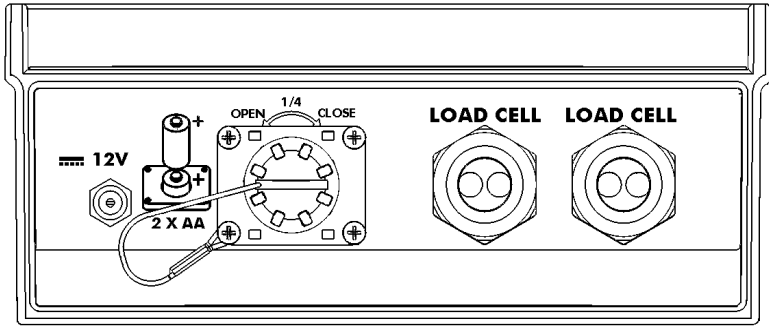

**Connecting Load Cell Wires in Indicator**

- Remove the back cover (nine screws)
- Feed the load cell wires in through the liquid-tight connectors
- Connect two wires to each terminal as shown. Tighten snugly.
- Install the back cover (nine screws)

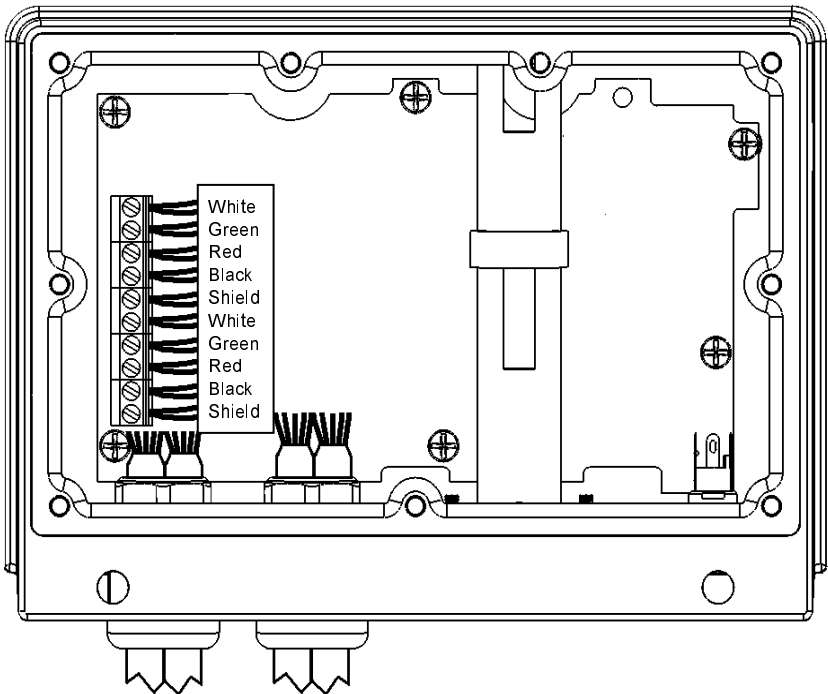

# OPERATION

## Turn on Indicator



1. Press .

## Zero Balance Indicator

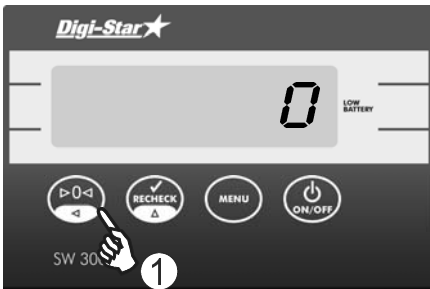

1. Press and hold  to zero balance the indicator.

## Weighing Animals

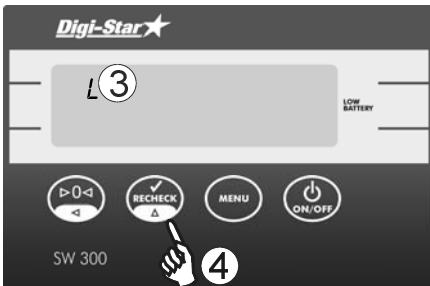

2. Place animal on platform.
3. "L" on the left side of the display indicates that the weight is "Locked-On".
4. Press  while animal is on scale to "re-weigh" the animal.

## Turning Off the Indicator

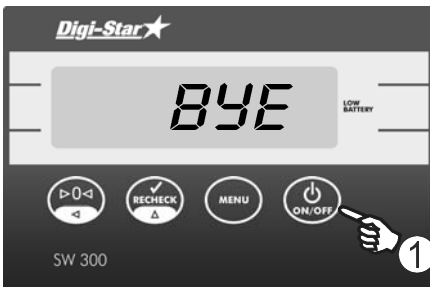

1. Press  until "BYE" is displayed.

# OPTIONAL SETTINGS

## Load Cell Setup



1. Press and hold and at the same time until *SETUP* is shown.
2. Press to advance through selections
3. Press to save.

	Description	CAP (lbs)
<i>3300LB</i>	StockWeigh 3300 (pounds)	4,000
<i>6600LB</i>	StockWeigh 6600 (pounds)	7,000
<i>584 LB</i>	StockWeigh 1250 (pounds)	10,000
<i>10K LB</i>	StockWeigh 10000 (pounds)	10,000
<i>14K LB</i>	StockWeigh 14000 (pounds)	15,000
<i>3300KG</i>	StockWeigh 3300 (kilograms)	1,999
<i>6600KG</i>	StockWeigh 6600 (kilograms)	2,999
<i>584 KG</i>	StockWeigh 1250 (kilograms)	5,000
<i>10K KG</i>	StockWeigh 10000 (kilograms)	5,000
<i>14K KG</i>	StockWeigh 14000 (kilograms)	6,999
<i>OTHER</i>	Other load cell (Use Dead Weight Cal.)	_____

# OTHER FUNCTIONS

## Backlight Settings

The Backlight can be set of one of the following settings. When set to TIME, the backlight turns off ten seconds after the last key-press.

OFF	BACKLIGHT IS OFF
TIME 1	TIME = BACKLIGHT WILL TURN OFF
TIME 2	10 SECONDS AFTER THE
TIME 3	LAST KEY PRESS
TIME 4	1 - 5 = BACKLIGHT BRIGHTNESS
TIME 5	1 = LOW/DIM
	5 = BRIGHTEST BACKLIGHT

ON 1	BACKLIGHT <u>WILL NOT</u> TURN OFF
ON 2	1 - 5 = BACKLIGHT BRIGHTNESS
ON 3	1 = LOW/DIM
ON 4	5 = BRIGHTEST BACKLIGHT
ON 5	

## Change the Backlight Setting

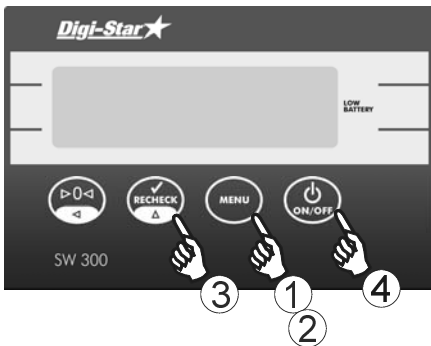

1. Press and hold **MENU** for 3 seconds (**ZTRACK** is shown).
2. Press **MENU** repeatedly until **BAKLIT** is shown. The current backlight setting will be displayed.
3. Press **RECHECK** repeatedly until the desired setting is displayed.
4. Press **ON/OFF** to save the setting.

## **WEIGH METHODS**

Select “Lock On” for animal weighing. Use “General” for general weighing.

### **General Weigh Method**

All purpose weigh method for weighing stable loads. It does not “Lock On” the weight.

### **Lock-on Weigh Method**

Weighs active animals and displays stable accurate weight. Lock-On sensitivity is adjusted using “LOCKON” menu (see page 13).

- Scale “Locks-On” to weight.
- Weight is displayed stable, even if motion never stops.
- Small ‘L’ appears on left side of display indicating weight is “Locked-On”.
- Animal’s weight must be greater than 0.67% of scales “capacity” (CAP) before system can “Lock-On”.

Example: If “CAP” = 4000, 27 lbs. or more is required for scale to lock-on.

*Note: Use a weight value for Zero Tracking (ZTRALCK) (see page 13) that is less than 0.67% of capacity.*

To break lock, add or remove WEIGHT FROM SCALE PLATFORM. The default setting is 50%.

- The weight value that is used to “break the lock” and return to normal weighing can be selected by choosing a value from 01 to 99%. (see page 13) For example, if unlock is set to 10(%) and weight is locked at 1000, display will “unlock” and return to normal weighing at 900, once 10% (100) is removed.
- “Locked-On” weight can be “rechecked”, press  this breaks “lock” and scale recalculates weight.

## WEIGHING ERRORS

### Over Capacity Limit (*OVERCAP*)

- Weight on scale exceeds capacity limit. Capacity value is entered in SETUP to warn of overloading.

### Over Range (*+RANGE*)

- The display shows message "+RANGE" if weight on scale system exceeds maximum weight measurable by scale system.

### Under Range (*-RANGE*)



- Display shows message "-RANGE" if weight on scale system is less than minimum weight measurable by scale system.

## RUN SELF TEST

Displays diagnostic tests to aid in troubleshooting.

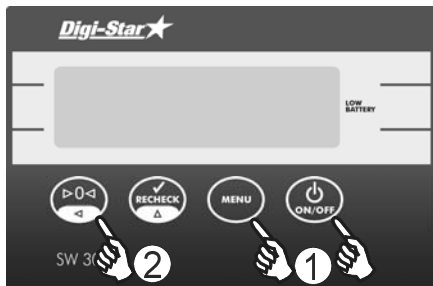
- Shows battery level
- Shows load cell setup
- Tests display segments
- Shows program ID
- Allows key test



1. Press  and within three seconds press  to start self test.
2. Press  to exit test.



# MENUS AND CALIBRATION

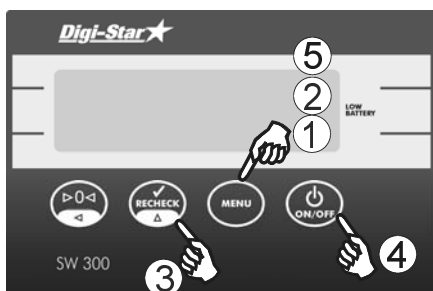

1. Press and hold **MENU** for 3 seconds.
2. Press **MENU** repeatedly until desired setting shows.
3. Press **RECHECK** to change setting option.
4. Press **MENU** to save setting and advance to next setting.
5. Press **MENU** repeatedly until indicator returns to weighing mode.

SETTING [display]	Options [display] BOLD = DEFAULT	DESCRIPTION
Zero Tracking (ZTRACK)	1-99/ <b>OFF</b>	Adjusts to zero for build-up of snow, mud and manure. Weight value can be set from 1 to 99 lbs/kgs or OFF (00)
Weigh Method (W MTHD)	GENERAL, <b>LOCK</b>	Select weight method.
Lock-On (LOCKON)	0.50, 0.75, 1.00, 1.25, 1.50, 1.75, 2.0, <b>5.0</b> , 10.0	Higher value will lock on quicker but sacrifice accuracy. Use lowest setting that will consistently lock-on to the same weight for a restless animal.
Unlock	01-99( <b>50%</b> )	The percent of weight required to break the lock and return to normal weighing.
Lock-N-Hold (LKNHLD)	<b>ON/OFF</b>	Holds "Lock-On" weight restarts when next animal steps on.
Auto Off (AUTOFF)	15,30,45,60, <b>OFF</b>	Indicator shuts "OFF" after set period of inactivity.
Display Count (COUNT)	.01,.02,.05,.1,.2,.5, <b>1,2,5,10,20,50,100</b>	Select display count size (resolution) of scale.
Auto-Range (RANGE)	<b>ON/OFF</b>	Scale increases display count size for weights over 300 again at 600 lbs/kgs.
Display Unit (LB-KG)	<b>LB/KG</b>	When changing weight unit calibration adjusted so scale displays accurately in new display unit.

SETTING [display]	Options [display] BOLD = DEFAULT	DESCRIPTION
Capacity (CAP)	<b>04000</b>	Enter maximum weight measurable.
Span (SPAN)	75%-125%	Displayed weight value can be adjusted by increasing or decreasing the <i>SPAN</i> percentage.
Back Light (BCKLIT)	OFF TIME 1 TIME 2 <b>TIME 3</b> TIME 4 TIME 5 ON 1 ON 2 ON 3 ON 4 ON 5	Backlight intensity, see page 10.

## Calibrating Scale Using Known Weights



1. Press and hold and at the same time to enter setup menu.
2. Press repeatedly to scroll down to *OTHER* and press .
3. Press to zero balance the scale.

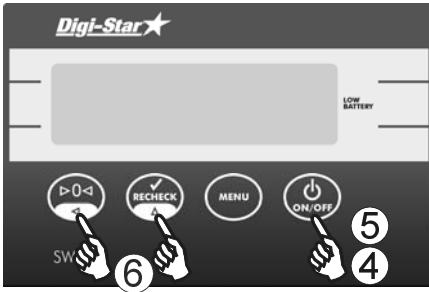

4. Then press .
5. Add a known weight and press .
6. Change displayed weight by pressing to change value of "flashing" digit and press key to select which digit of display is flashing.

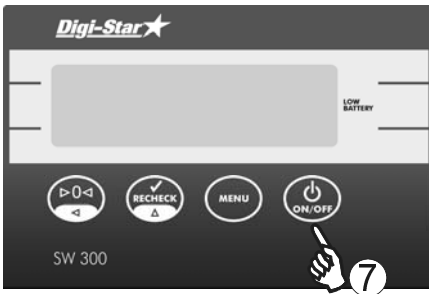

7. When display reads correct weight, press to store calibration value.

# INSTALLATION

## Indicator Mounting

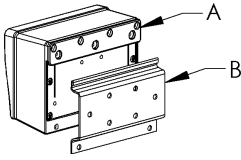
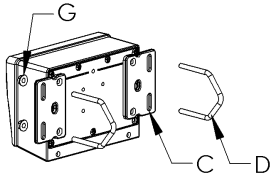
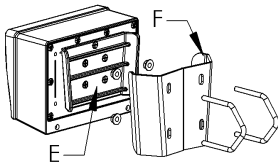
					
RAIL MOUNT		WING MOUNT		WEDGE MOUNT STANDARD	
KEY	PART NUMBER	DESCRIPTION			
A	403769	BRACKET – STR TOP MOUNT			
B	403980	BRACKET – ROBO MOUNTING			
C	403770	BRACKET – WING MOUNT			
D	405069	U-BOLT, 1/4-20 X 3.25 ZP			
E	403771	MODIFIED PLASTIC WEDGE MOUNT			
F	405124	WEDGE MOUNT BRACKET, INCLUDES U-BOLTS & NUTS			
G	405084	NUT, 1/4-20 TOP LOCKING FLANGE			

## Optional Ram Mounting

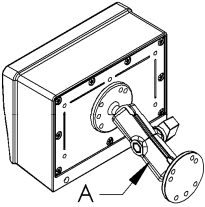
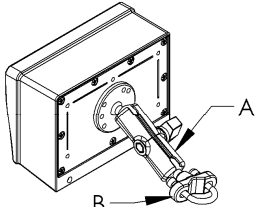
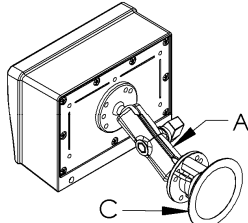
					
RAM MOUNT STANDARD		U-BOLT BASE		TWIST LOCK SUCTION CUP	
KEY	PART NUMBER	DESCRIPTION			
A	403180	RAM MOUNT			
B	403179	MOUNT BASE-1" BALL U-BOLT			
C	404230	RAM SUCTION CUP W/TWIST LOCK			

# TROUBLESHOOTING

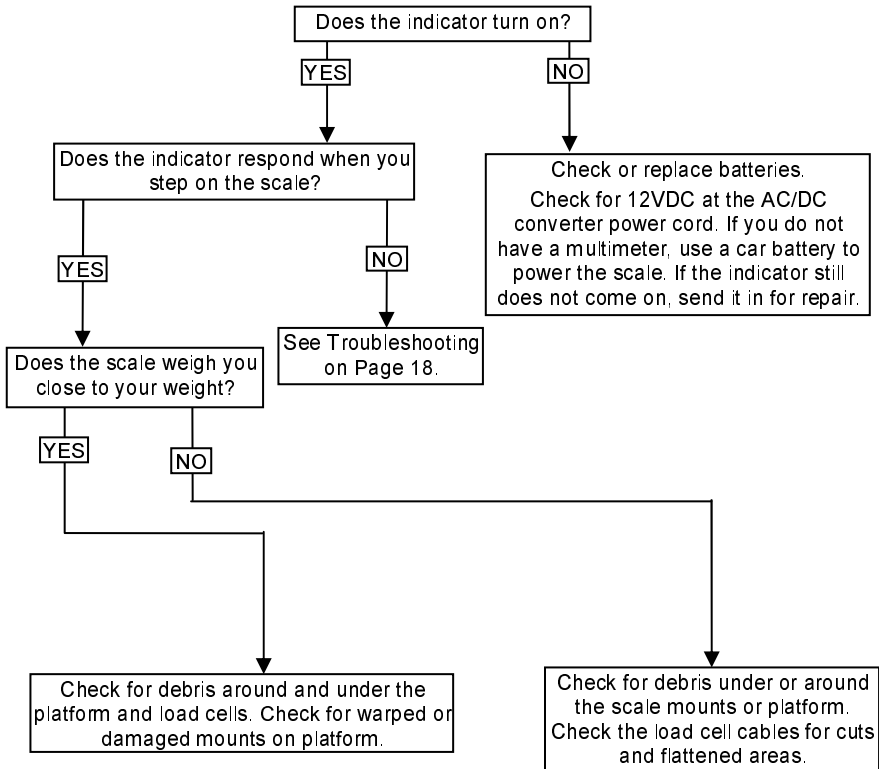

## Indicator Does Not Respond When You Step on the Scale

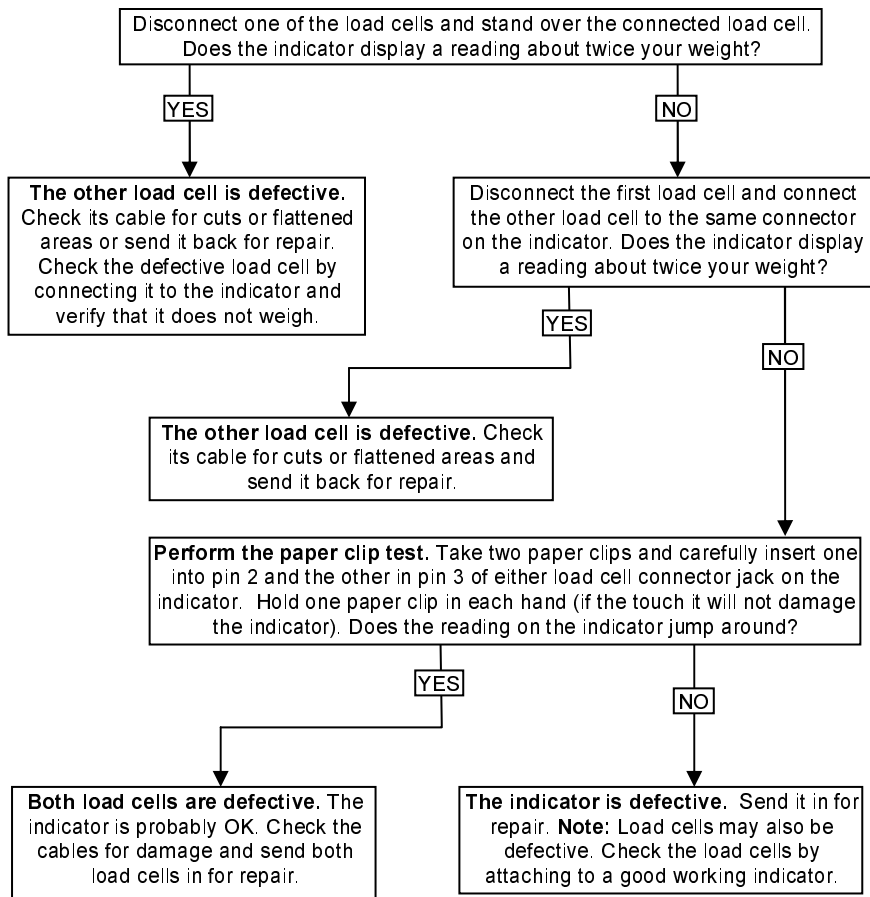

### The Scale Weighs Close to Your Weight

