



STOCK WEIGH SCALE HARDWARE

MODEL SW3300
MODEL SW6600
MODEL SW10,000
MODEL SW14,000

INSTALLATION AND OPERATION GUIDE



Ft. Atkinson, Wisconsin USA



Panningen, The Netherlands

www.digi-star.com

TABLE OF CONTENTS

INTRODUCTION.....	3
PRODUCT CHANGES AND IMPROVEMENTS.....	3
STOCK WEIGH SCALE COMPONENTS:.....	4
STOCKWEIGH SPECIFICATIONS	9
LOAD CELL DIMENSIONS	9
Model 3300	9
Model 6600	10
Model 10,000 Hybrid.....	11
Model 10,000	11
Model 14,000 Hybrid.....	12
Model 14,000	12
SW Platform – Wrangler – 90”	13
SW Platform – Wrangler Jr. – 54”	14
INSTALLATION.....	15
10K/14K Load Cells	15
J-box Installation	17
Wrangler JR Deck Assembly	18
MAINTENANCE	19
TROUBLESHOOTING GUIDE	20
TYPICAL WOOD PLATFORM CONSTRUCTION.....	23
Model 3300 (3300 LB [1500 KG] Gross Capacity).....	23
Model 6600 (6600 LB [3000 KG] Gross Capacity).....	24
REPAIR PARTS	25
STOCK WEIGH 3300	26
STOCK WEIGH 6600	27
Stock Weigh – 10,000 LBS	29
Stock Weigh – 14,000 LBS	30
J-Box Repair Parts.....	31
J-Box Repair Parts.....	32
Wedge Mount.....	33
WIRING DIAGRAM - LOAD CELL CONNECTOR.....	33

INTRODUCTION

Congratulations on your purchase of a Digi-Star Stock Weigh scale system which is the simplest and most reliable animal weighing system on the market today. Due to the large number of load cell capacity options, Stock Weigh scale systems can be customized to fit your animal weighing needs. The indicator Auto-Lock feature allows scale to weigh active and restless animals within $\pm 1\%$ of actual weight. This manual will cover load cell and other hardware options available in Stock Weigh system. The load cells option available include following: SW3300 (3300 lbs capacity), SW6600 (6600 lbs Capacity), SW10K (10,000 lbs capacity), SW14K (14,000 lbs capacity).

PRODUCT CHANGES AND IMPROVEMENTS

We reserve the right to make changes in design, to add improvements to or otherwise modify our electronic scale products without incurring an obligation on goods previously purchased and to discontinue supplying any parts listed when the demand does not warrant production.

STOCK WEIGH SCALE COMPONENTS:

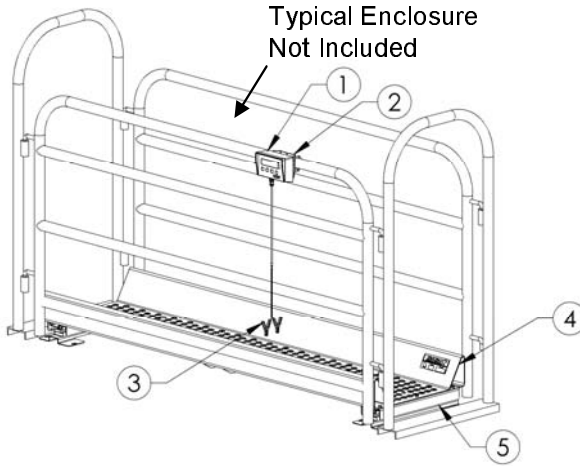

KEY 1 - INDICATORS



KEY	PART NUMBER	DESCRIPTION
A	SW300 BATTERY OPERATED	
	404914	SW300 SCALE W/ 2 LOAD CELL CONNECTOR & WEDGE MOUNT
	404915	SW300 SCALE FOR 2 BARE LEAD LOAD CELL CABLES & WEDGE MOUNT
	405408	SW300 SCALE FOR 4 BARE LEAD LOAD CELL CABLES & WEDGE MOUNT
B	403778	SW600 SCALE
C	404588	SW2600 SCALE
D	404589	SW4600EID SCALE
E	405147	HORIZON XL
	405148	HORIZON XLS
	405149	HORIZON XLT

KEY 2 - INDICATOR MOUNTING – FOR SW300 & SW600 SHIPPED WITH WEDGE MOUNT AS STANDARD

RAIL MOUNT		WING MOUNT	WEDGE MOUNT STANDARD
KEY	PART NUMBER	DESCRIPTION	
A	403769	BRACKET – STR TOP MOUNT	
B	403980	BRACKET – ROBO MOUNTING	
C	403770	BRACKET – WING MOUNT	
D	405069	U-BOLT, 1/4-20 X 3.25 ZP	
E	403771	MODIFIED PLASTIC WEDGE MOUNT	
F	405124	PACK – WEDGE MOUNT BRACKET, INCLUDES U-BOLTS & NUTS	
G	405084	NUT, 1/4-20 TOP LOCKING FLANGE	

KEY 2 - OPTIONAL RAM MOUNTING BRACKET OPTIONS FOR SW300 & SW600

RAM MOUNT STANDARD		U-BOLT BASE	TWIST LOCK SUCTION CUP
KEY	PART NUMBER	DESCRIPTION	
A	403180	RAM MOUNT	
B	403179	MOUNT BASE-1" BALL U-BOLT	
C	404230	RAM SUCTION CUP W/TWIST LOCK	

**KEY 2 - INDICATOR MOUNTING – FOR EZ2600 & EZ4600EID
SHIPPED WITH WEDGE MOUNT AS STANDARD**

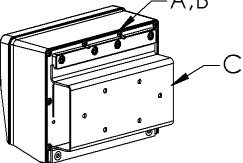
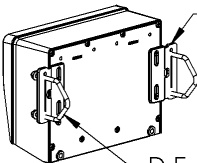
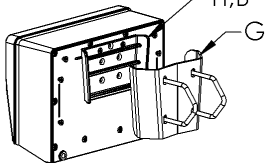
					
RAIL MOUNT		WING MOUNT		WEDGE MOUNT (STANDARD)	
KEY	PART NUMBER	DESCRIPTION			
A	404353	BRACKET-EZ3 PLASTIC RAIL			
B	403780	SCR-#10 X 5/8 FHSTS BLACK ZP			
C	840459	SUPPORT-HAT BRACKET			
D	405069	U-BOLT 1/4-20 X 3.25 ZP			
E	405084	NUT-1/4-20 TOP LOCKING FLANGE			
F	403770	BRACKET- WING MOUNT			
G	405124	PACK-WEDGE MOUNT BRACKET WITH U- BOLTS & FLANGE NUTS			
H	405052	BRACKET-MODIFIED WEDGE MOUNT (FACTORY INSTALLED)			
	405244	PACK-EZ3 WEDGE MOUNT (FIELD INSTALLED)			

**KEY 2 - OPTIONAL RAM MOUNTING BRACKET OPTIONS
EZ2600 & EZ4600EID**

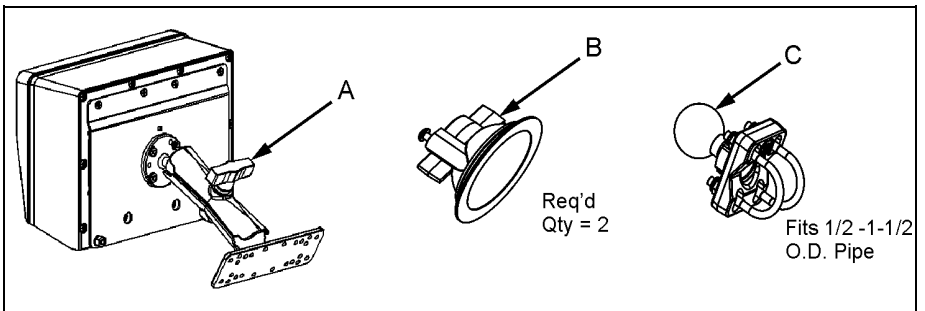

KEY	PART NUMBER	DESCRIPTION
A	404799	PACK-RAM 1.5 DIA KIT FOR EZ3 INDICATOR WITH MOUNTING HARDWARE
B	404230	RAM MOUNT SUCTION CUP WITH TWIST LOCK
C	406981	MOUNT – 1.5 RAM WITH U-BOLT

KEY 3 - POWER SUPPLY OPTIONS – BOTH SUPPLIED W/ ALL INDICATORS

KEY	PART NUMBER	DESCRIPTION
A	404777	BATTERY CLIP ADAPTER, 9' LONG
B	148156	WALL OUTLET, 12VDC OUTLET, 5'6" LONG
C1	406507	AC/DC CONVERTER (NOT ILLUSTRATED) "SW300 ONLY"
C2	406508	AC PLUG (NOT ILLUSTRATED) "SW300 ONLY"

KEY 4 - PLATFORM OPTIONS

KEY	PART NUMBER	DESCRIPTION
A	403360	STOCK WEIGH ALLEY PLATFORM
B	405043	WRANGLER JR PLATFORM – INCLUDES INDICATOR STAND & RAM MOUNT

KEY 5 - LOAD CELL OPTIONS

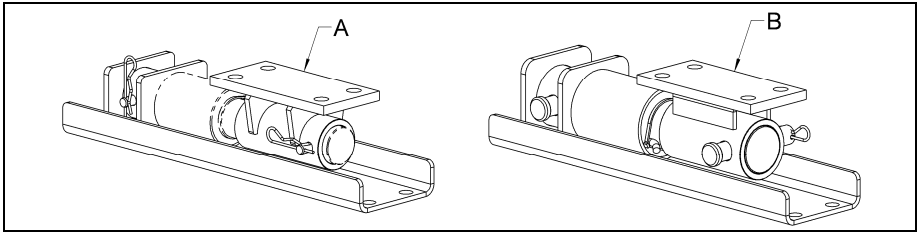

KEY	PART NUMBER	DESCRIPTION
A	405536	PACK 10K MOUNT FOR QTY 1 MNT (W/O LOAD CELL)
B	405537	PACK 14K MOUNT FOR QTY 1 MNT (W/O LOAD CELL)

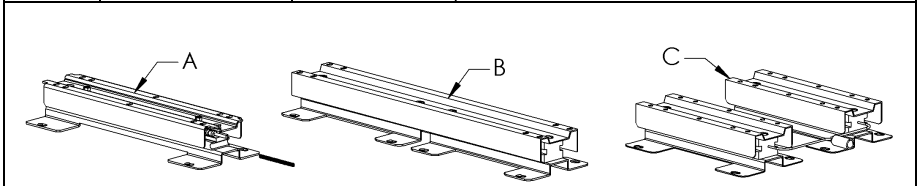

KEY	PART NUMBER	DESCRIPTION
A	148042	MODEL SW3300 16"
	406700	16" W/ CABLE GUARD
	146769	24"
	405105	24" W/ CABLE GUARD
	400144	33.5"
	407015	33.5" W/ CABLE GUARD
B	400058	MODEL SW6600 33.5"
	407025	33.5" W/ CABLE GUARD
	400006	44"
	407022	44" W/ CABLE GUARD
C	403441	MODEL SW6600 PAIRED VERSION 16"
	407032	PAIRED VERSION 16" W/ CABLE GUARD

STOCKWEIGH SPECIFICATIONS

Gross Capacity		Resolution (For Both Models)	
Model 3300:	3300 lbs. Max	<u>Increment</u>	<u>Range</u>
Model 6600:	6600 lbs. Max	1 lbs or kgs	0-300 lbs or kgs
Model 10000	10,000 lbs. Max	2 lbs or kgs	300-600 lbs or kgs
Model 14000	14,000 lbs Max	5 lbs or kgs	600 ⇄ lbs or kgs
Accuracy:	±1% and ±1Display	Power Requirements: 12-14 VDC @	
Increment		approx 1 Amp (SW300-2-AA Batteries)	
Load Cell Cable Length:	14 Feet	AC to DC Converter	
		110 VAC to 13.8VDC @ 1.2 Amps	

LOAD CELL DIMENSIONS MODEL 3300

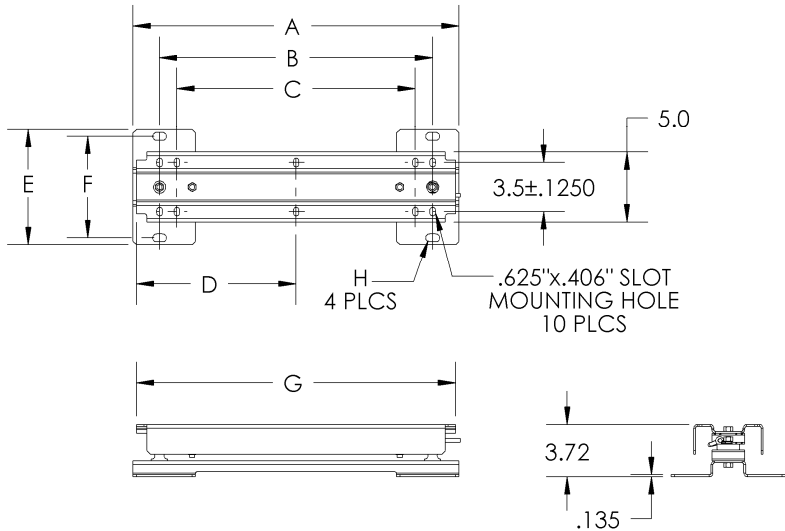

SW3300	A	B	C	D	E	F	G	H
406700/ 148042 16"	16"	12.19"	N/A	7.75"	8.25"	7.25"	15.5"	.625" X 1.0" SLOT
405105/ 146769 24"	23.5"	19.69"	17.19"	11.5"	8.25"	7.25"	23"	.562" X 1.0" SLOT
407015/ 400144 33.5"	32.5"	28.75"	23.5"	N/A	8.25"	7.25"	33.5"	.562" X 1.0" SLOT

MODEL 6600

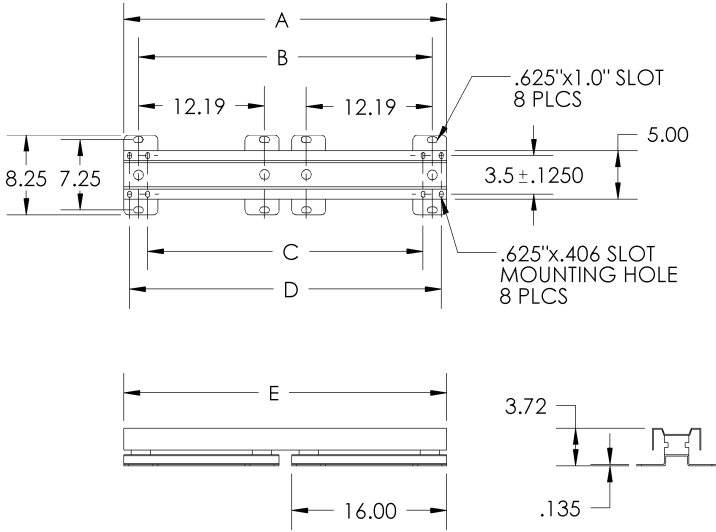

SW6600	A	B	C	D	E
407025/ 400058 33.5"	33.31"	29.5"	28.75"	32.5"	33.5"
407022/ 400006 44"	43.81"	40.0"	N/A	43.0"	44.0"

MODEL 10,000 HYBRID
(BEFORE JUNE 2009)

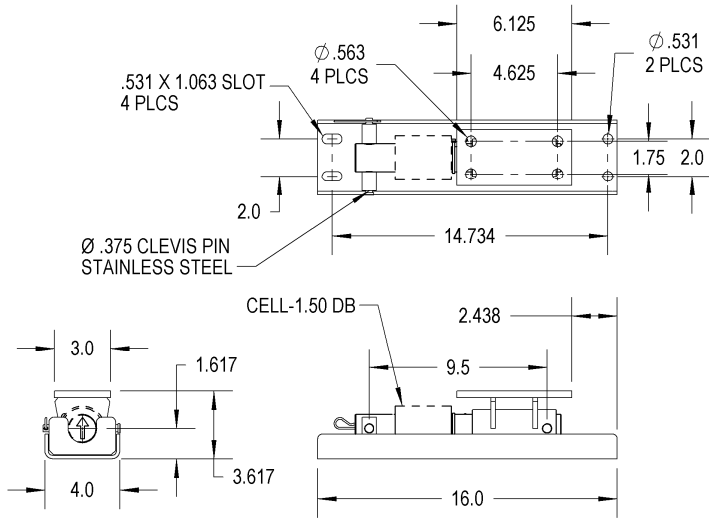

MODEL 10,000

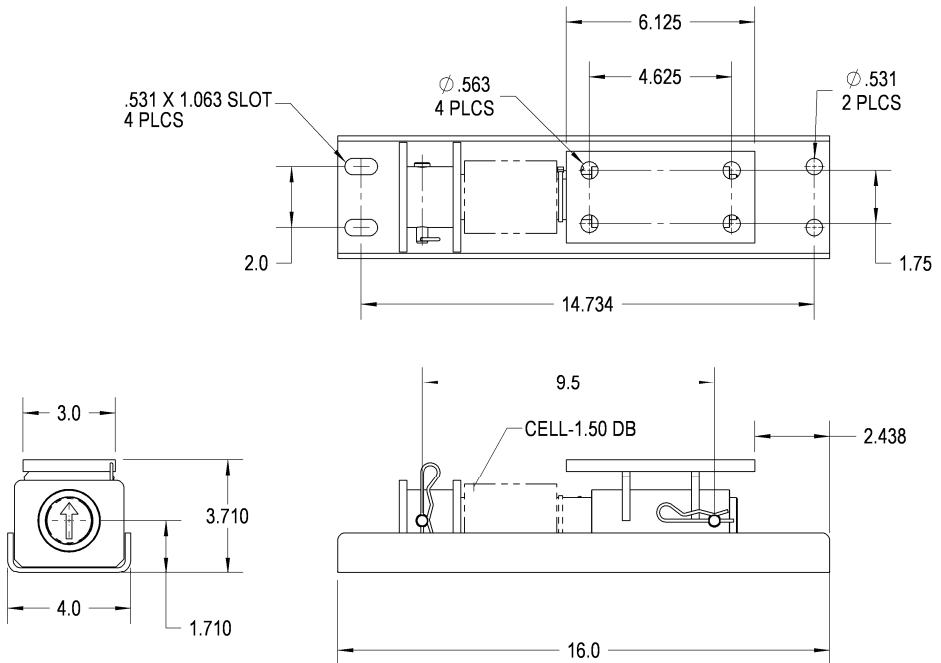

MODEL 14,000 HYBRID
(BEFORE FEBRUARY 2009)

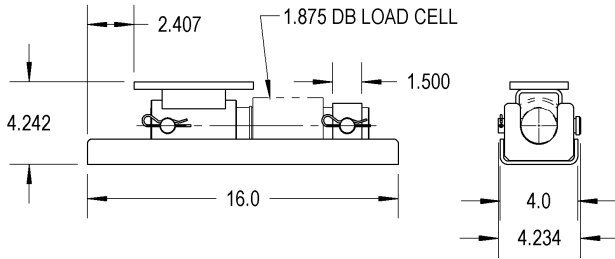
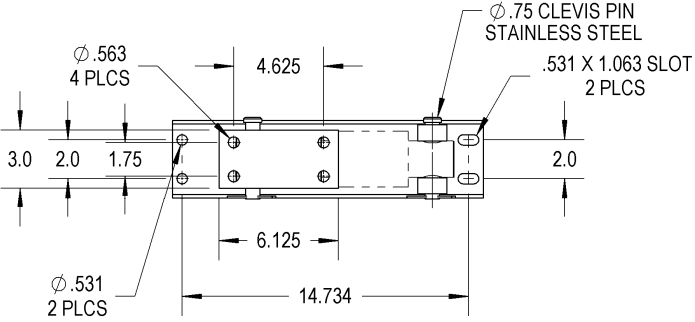

MODEL 14,000

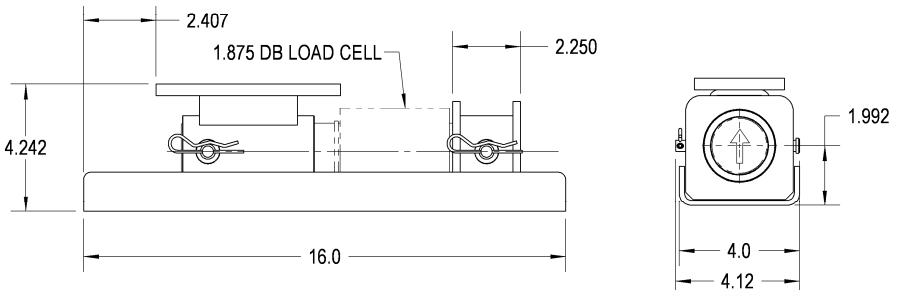
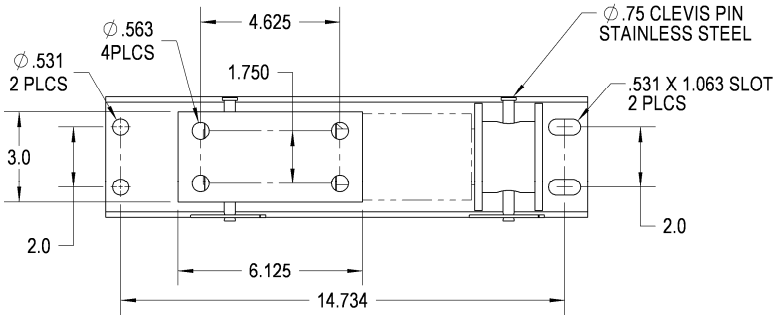

SW PLATFORM – WRANGLER – 90”

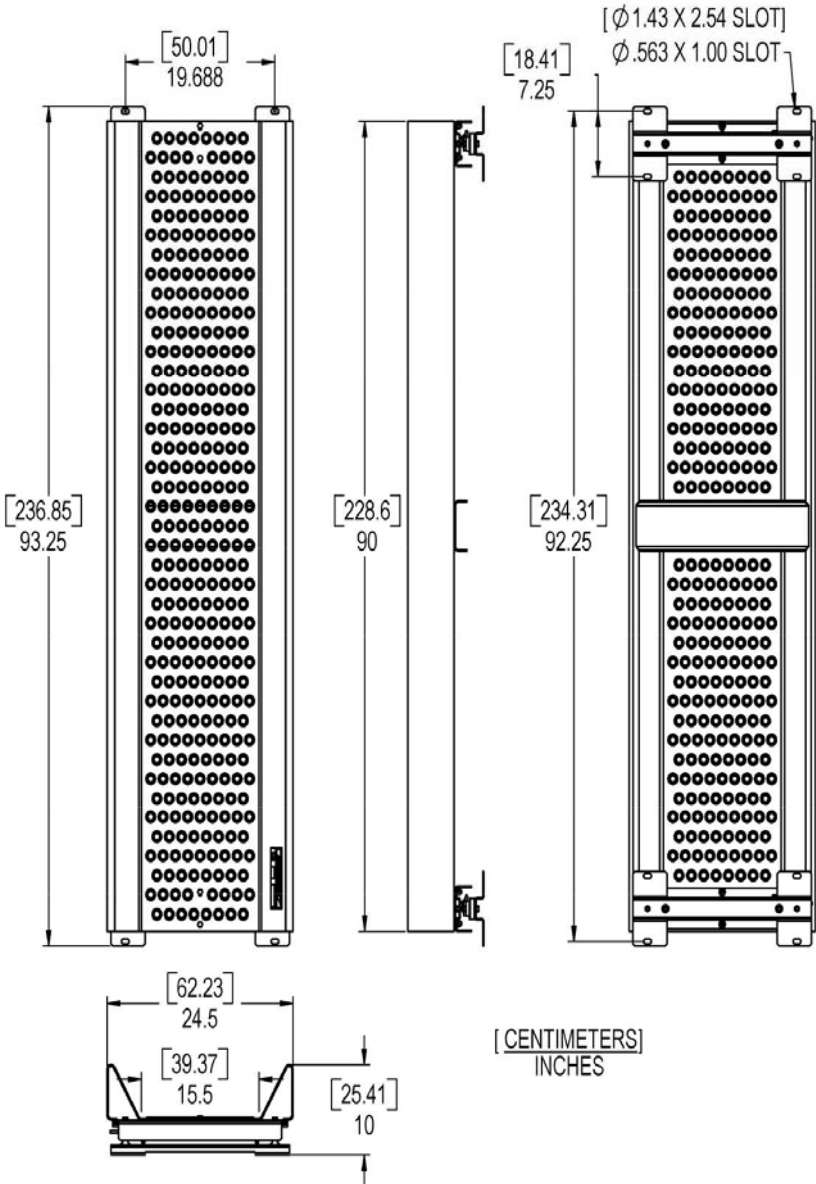

SW PLATFORM – WRANGLER JR. – 54”

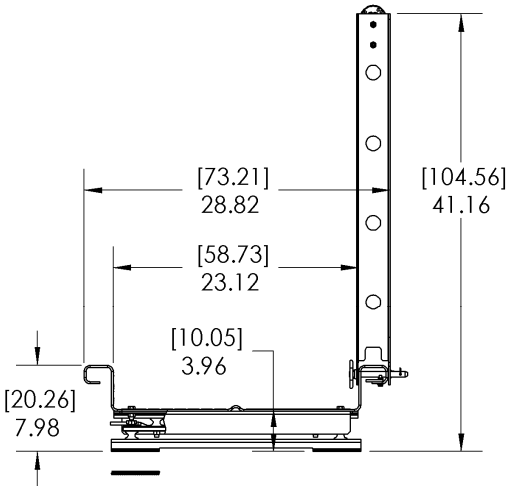
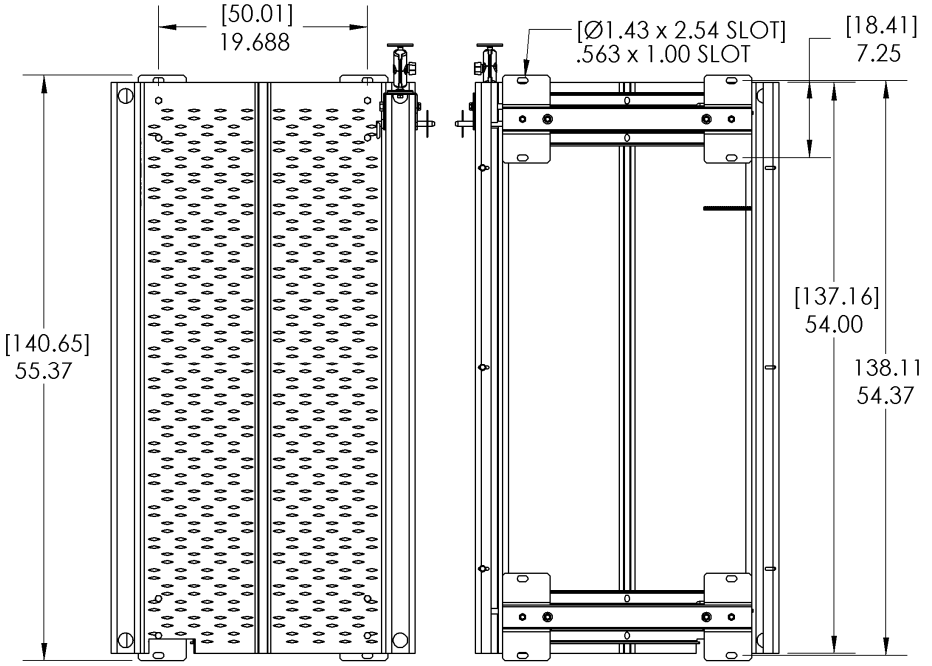

[CENTIMETERS]
INCHES

INSTALLATION

10K/14K LOAD CELLS

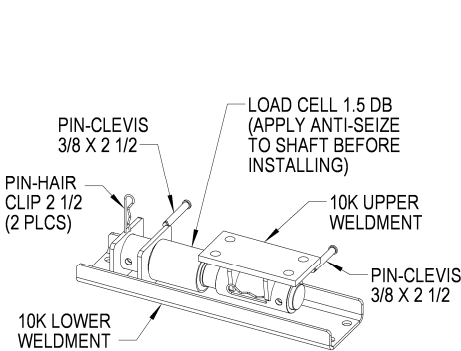
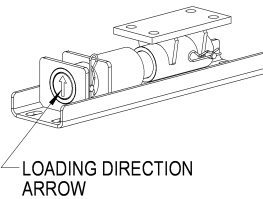
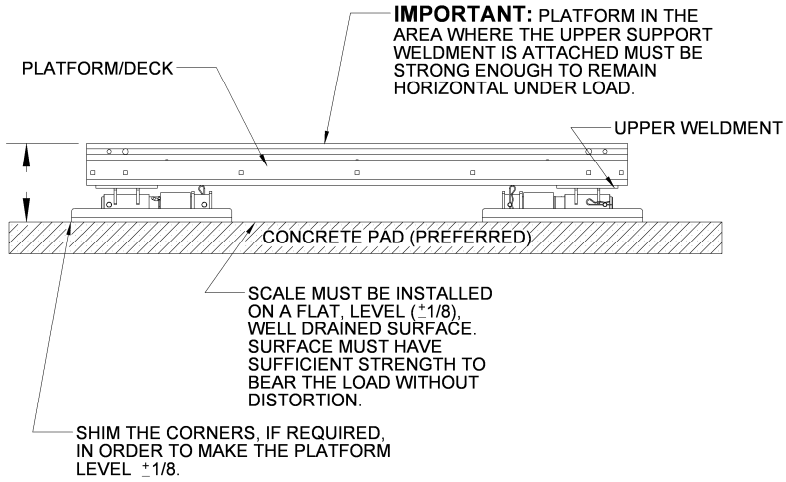

10K Mount

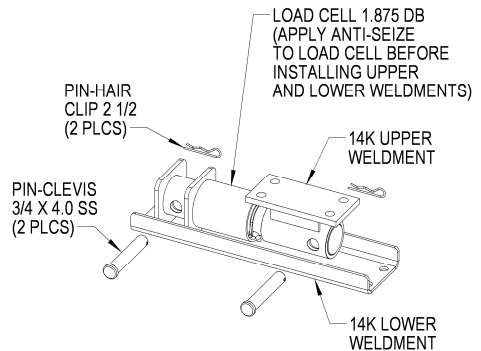

14K Mount

Install all load cells either widthways across the chute or lengthways parallel to the chute.

Align load cells so centerlines are lined up (or within ½" (12mm) of each other)

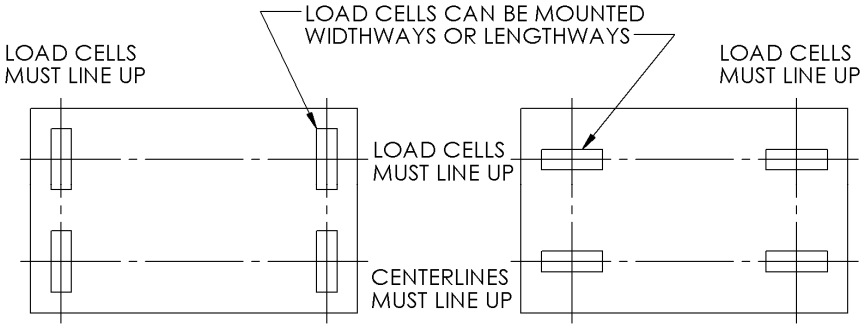

FOUR LOAD CELLS INSTALLED UNDER THE CHUTE/CRUSH

All load cells must be installed in the same direction so that weight is distributed evenly.

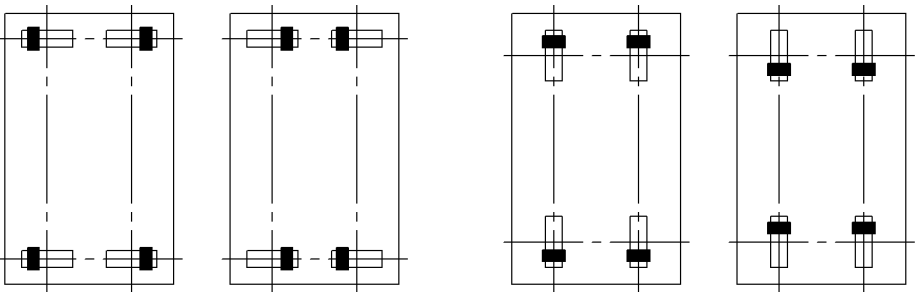

RECOMMENDED INSTALLATION CONFIGURATION

Each corner of the chute must be level for accurate weighing. This ensures that the load distributed equally.

IMPORTANT: Do Not weld to load cells with load cell cables connected to the indicator. If you must weld with load cells connected, locate welder ground so that current will not flow through the load cell.

J-BOX INSTALLATION [Lever-Nut Version]

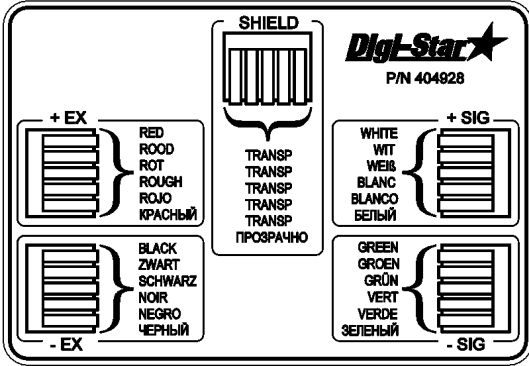

Decal – Lever Nut Wiring Instructions

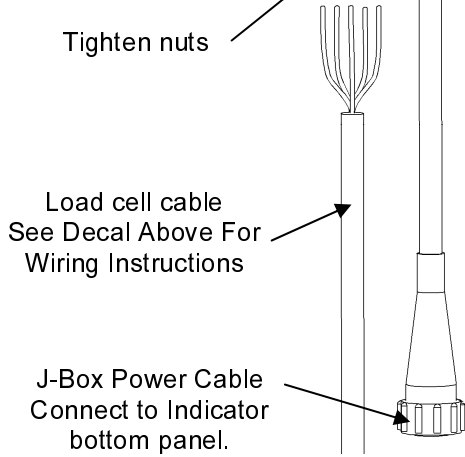
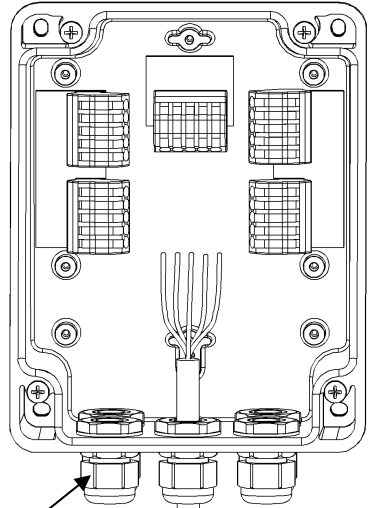

IMPORTANT: Do Not weld to load cells with load cell cables connected to the indicator. If you must weld with load cells connected, locate welder ground so that current will not flow through the load cell.

WRANGLER JR DECK ASSEMBLY

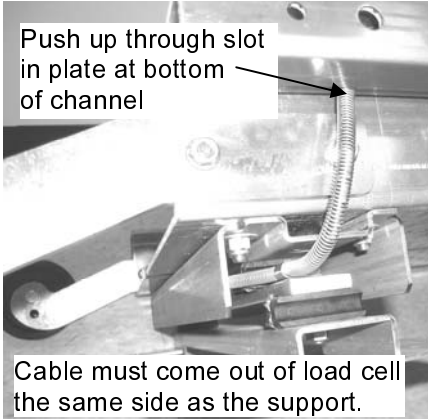

Figure 1. Load Cell Cable To Channel

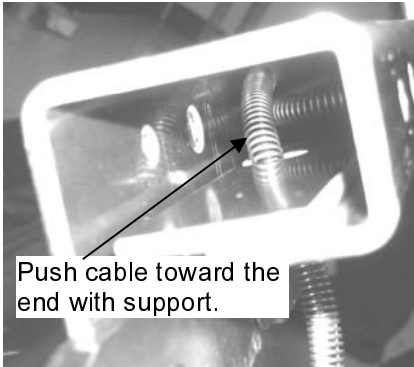

Figure 2. Cable Through Channel

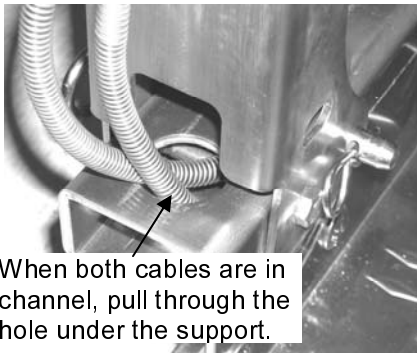

Figure 3. Cable Up From Channel To Support

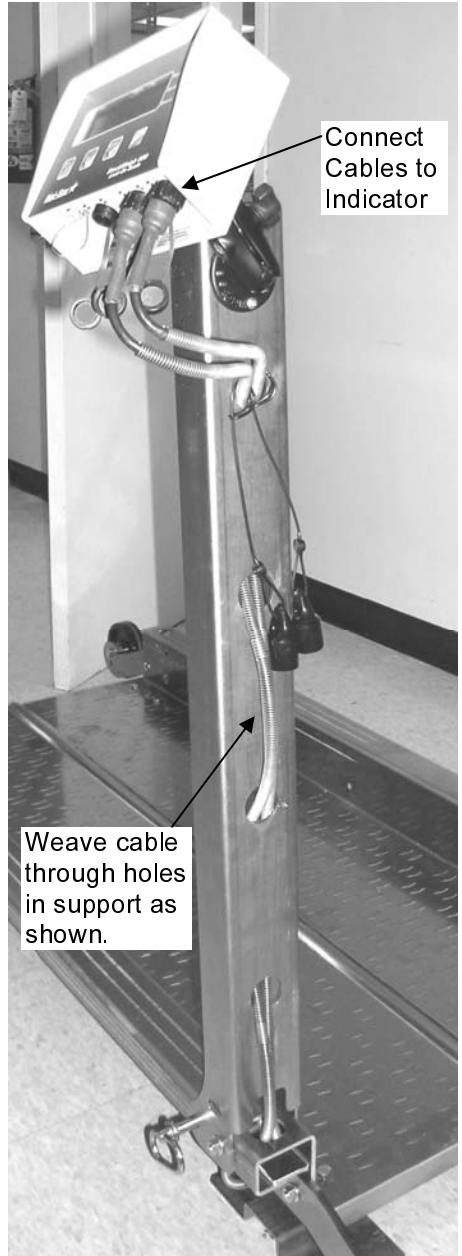

Figure 4. Cable Through Support To Indicator

Assemble load cells to deck as shown on page 25. Make sure both load cell cables come out the same side as the indicator support and the cable plate (located under one of the side channels).

Assemble indicator support, 1" ram mount and handle/wheels option as shown on page 25. The ram mount should be mounted on the channel support side which has the cable plate.

Load cell cable routing: Loosen cable retainer plate and push the plate outward. Begin by taking the two cable load cell connectors and feed them through the 1.5" diameter hole from the bottom toward the indicator support, Figure 3. Weave the load cell cable through the support arm toward the indicator, Figure 4. Attach the load cell connector to the indicator and pull any excess cable back down toward the deck.

At each load cell, push the cable through the retaining plate slot, Figure 1 and Figure 2. All extra cable is tucked inside the deck channel. When complete, push the cable retaining plate toward the deck to close off the channel. Tighten the three ¼" bolts to hold the retaining plate in position.

MAINTENANCE

There are no moving parts and no lubrication required. The only maintenance required is periodic cleaning of the mounts and the area below the scale to assure free and unencumbered operation of the scale. If a pressure washer is being used, do not spray or direct high pressure stream at the load cells. Load cell damage may occur.

Stand over each of the 4 corners to troubleshoot for problems. Corners should weigh the same within $\pm 1\%$ maximum error.

TROUBLESHOOTING GUIDE

STOCK WEIGH 3300, 6600, 10K, 14K WITHOUT J-BOX

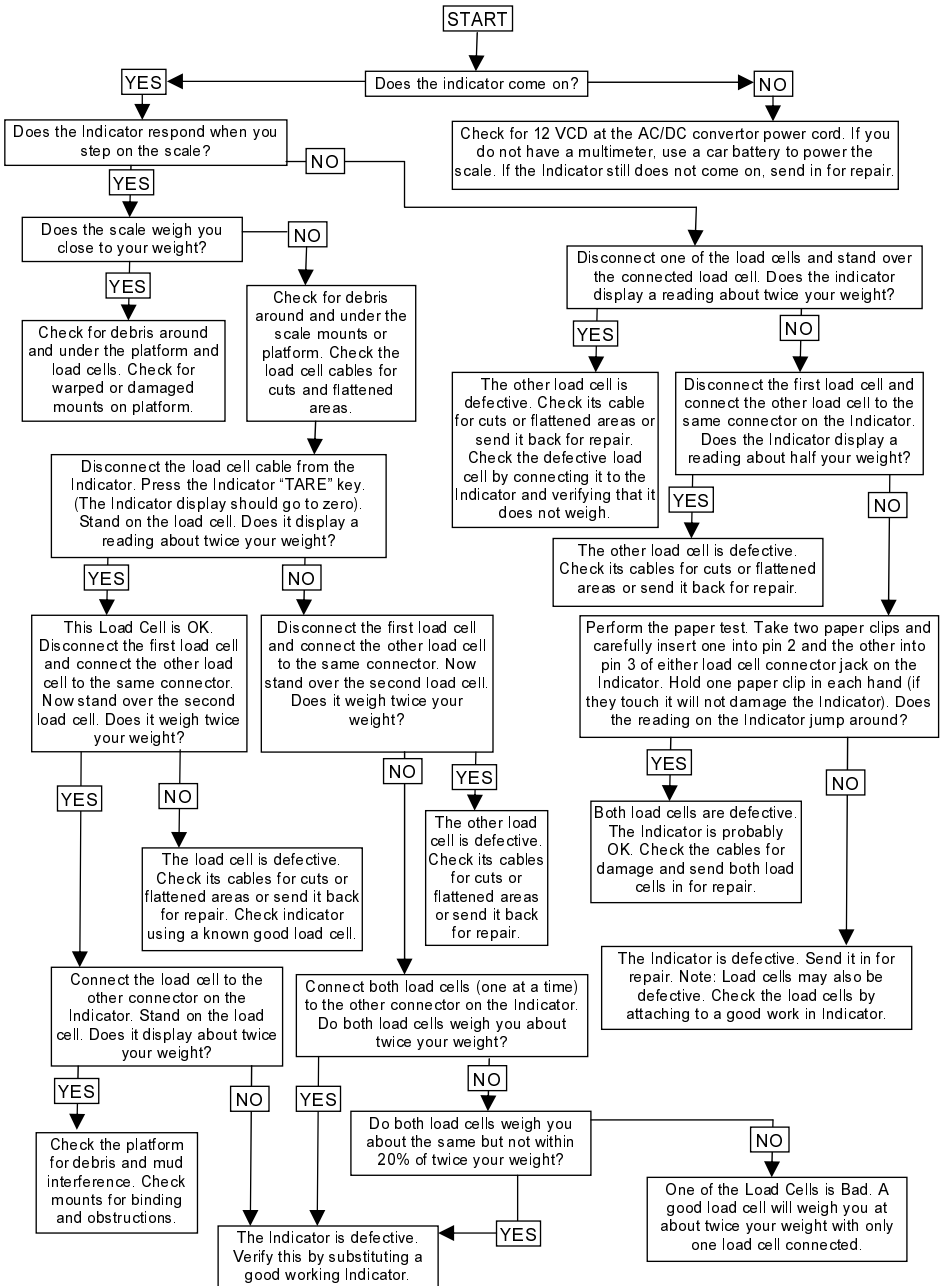

STOCK WEIGH 10K/14K WITH J-BOX

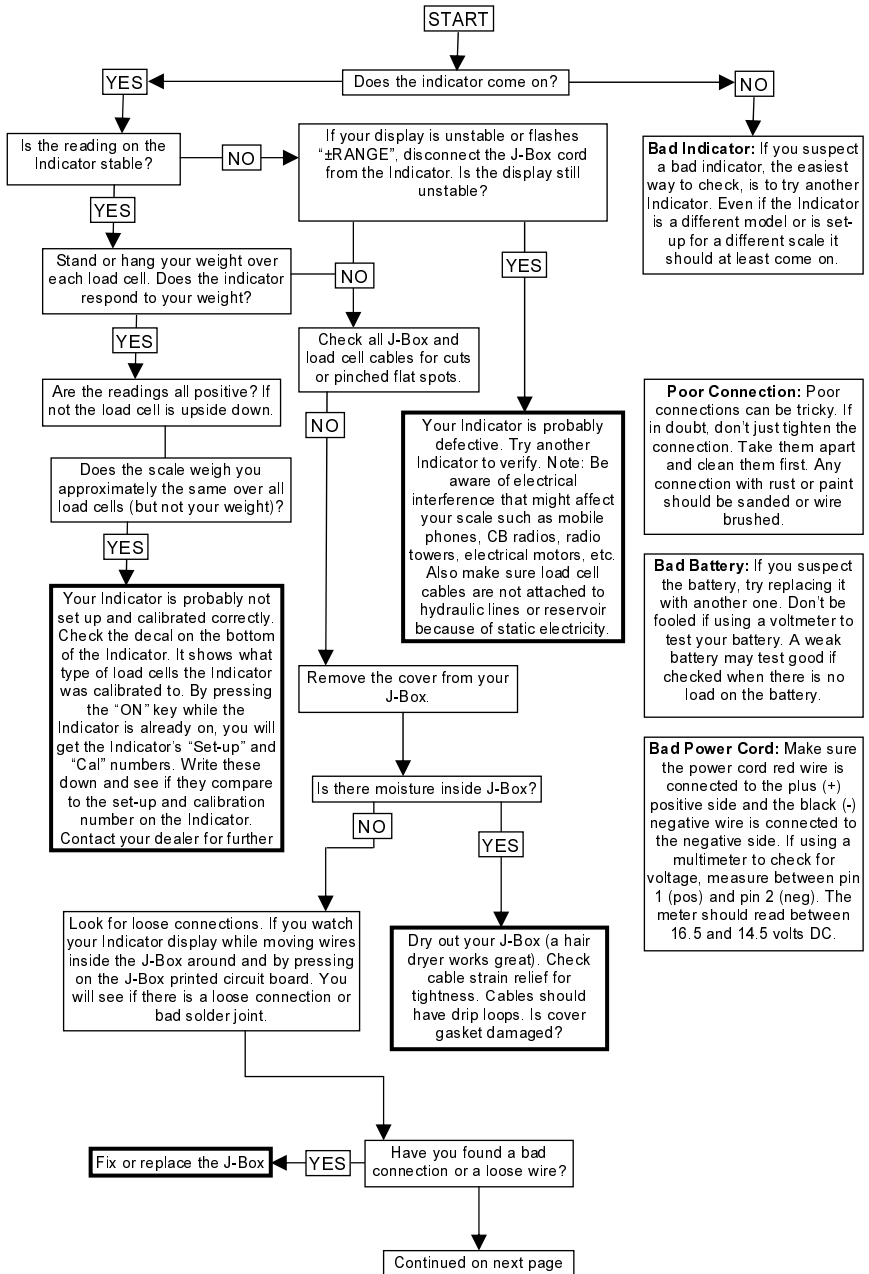

STOCK WEIGH 10K/14K WITH J-BOX

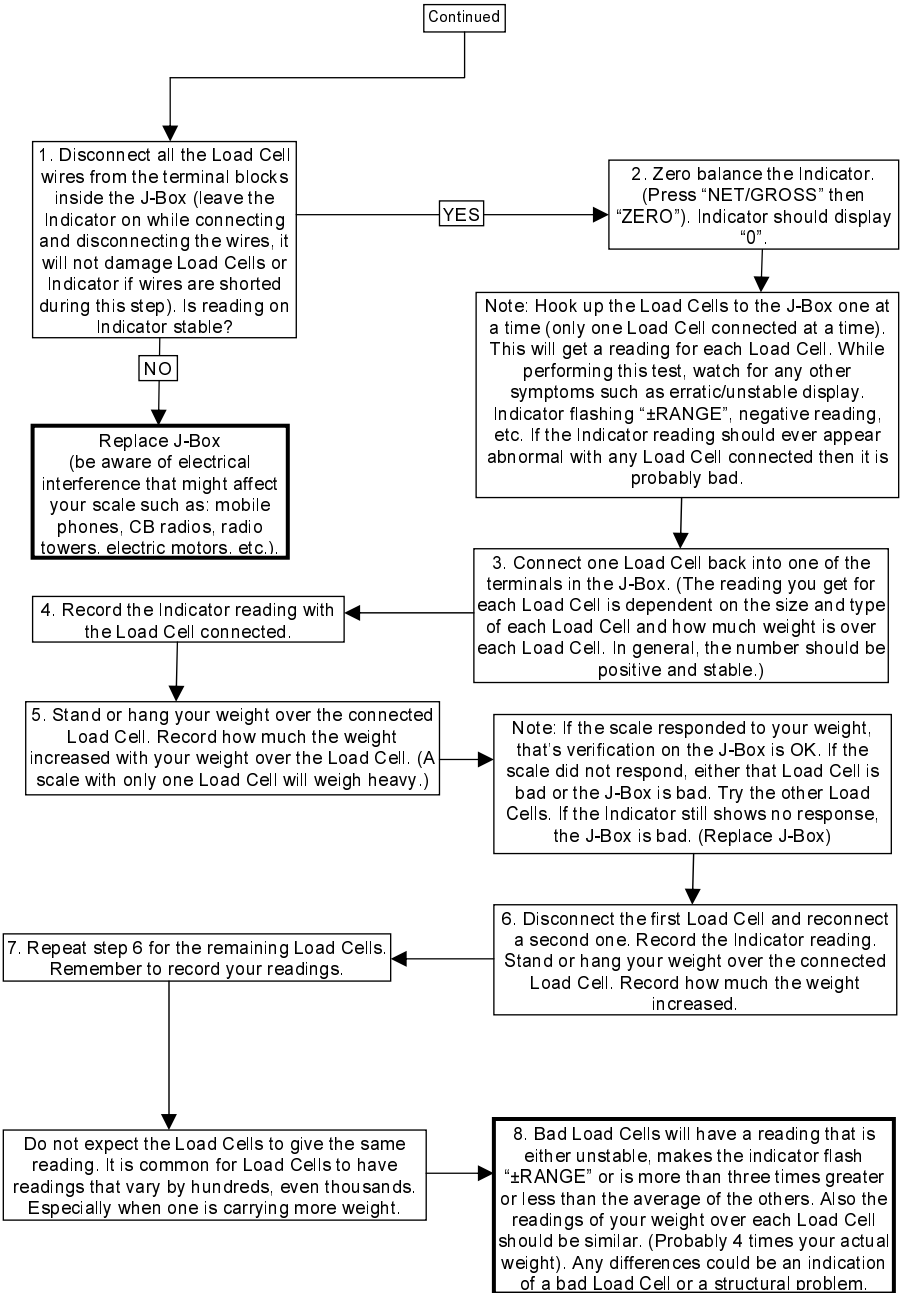

TYPICAL WOOD PLATFORM CONSTRUCTION

The following two platforms can be built using readily available building materials. Alternate decking material (plywood or steel grating) may be used if properly supported. An example of proper support could consist of either concrete or timber piers, or a concrete slab. Treated lumber is recommended for decking material.

If alternate deck sizes and/or materials are used, be aware that too much deck deflection will affect weighing accuracy. A heavy strong structure is better than a light one that flexes.

Important:

Do not weld to load cells with load cell cables connected to the indicator. If you must weld with load cells connected, locate welder ground so that current will not flow through the load cell.

MODEL 3300 (3300 LB [1500 KG] GROSS CAPACITY)

This is a typical platform that may be used with the Stockweigh Model 3300.

Do not allow deck to overhang more than 6 inches past the edge of the load cell.

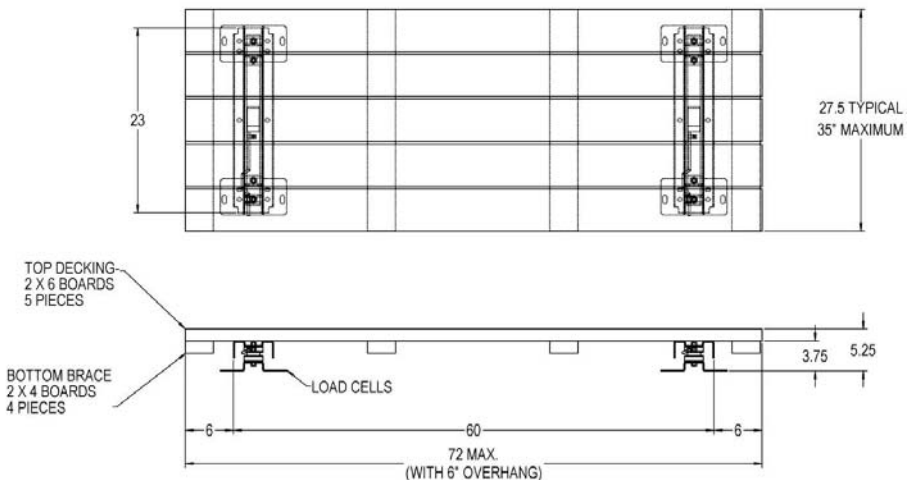

MODEL 6600 (6600 LB [3000 KG] GROSS CAPACITY)

This plan is an example of a platform that may be used with the Stockweigh Model 6600. Do not allow deck to overhang more than 12 inches past the edge of the load cell.

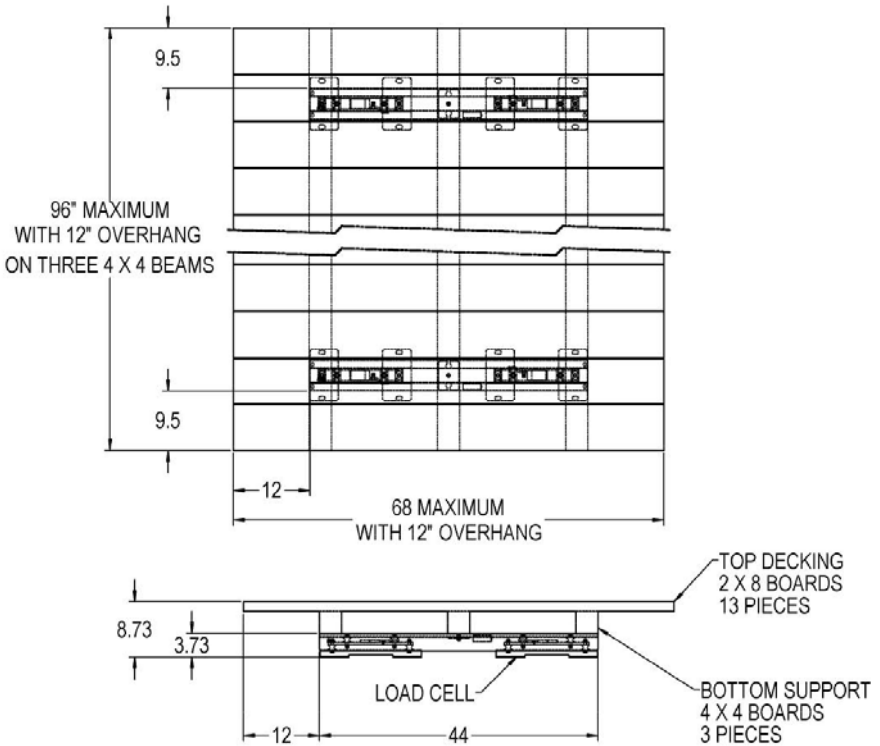

REPAIR PARTS
PLATFORM ASSEMBLY, WRANLGER JR
 P/N 405043

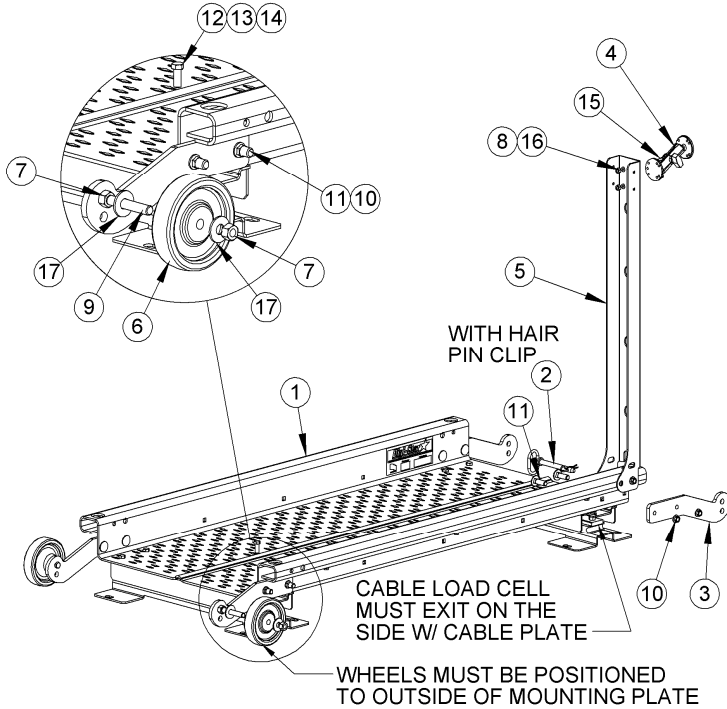

KEY	QTY	PART NO	DESCRIPTION
1	1	405121	ASSY-54" DECK WRANGLER JR
2	1	405081	PIN-HITCH 1/2 X 4.0 LEN ZP
3	4	405050	PLATE-SW DECK HANDLES
4	1	403180	ASSY-1" RAM MOUNT
5	1	405070	BRKT-INDICATOR SUPPT
6	2	405051	WHEEL-5.0 OD X .5 ID
7	4	404974	NUT-1/2-13 NC LOCK SS
8	2	405061	WASH-#10 FLAT ZP
9	2	405238	SCR -1/2-13 X 3.0 HHCS ZP GRD 5
10	9	404705	NUT-3/8-16 SER FLANGE ZP
11	8	405060	SCR- 3/8-16 X 1.0, CRG BOLT ZP GR2
12	8	400037	SCR-3/8-16 X 1.0 HHCS ZP GRD5
13	8	171610	WASH-3/8 TYPE A NARROW FLAT
14	8	404292	NUT - 3/8-16 NYLOC ZP
15	2	840494	SCR-RHMS #10-24 X 5/8 ZP
16	2	400401	NUT-#10-24 LOCK
17	4	405053	WASH-1/2 FLAT ZP
18	1	405080	SCR - 3/8-16 X 3.5 HHCS GRD 5 ZP

STOCK WEIGH 3300

W/O CABLE GUARD

148042
146769
400144

SW 3300 16"
SW 3300 24"
SW 3300 33.5"

W/ CABLE GUARD

406700
405105
407015

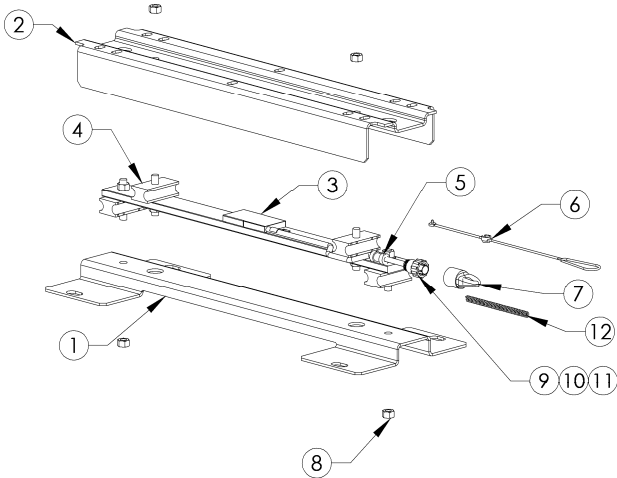

KEY	QTY	PART NO.	DESCRIPTION
1	1	400031	CHANNEL-LOWER – 16"
	1	400139	CHANNEL-LOWER – 24"
	1	400140	CHANNEL-LOWER – 33.5"
2	1	148039	CHANNEL-UPPER – 16"
	1	146762	CHANNEL-UPPER – 24"
	1	400059	CHANNEL-UPPER – 33.5"
3	1	148041	CELL-SW 13"- 15FT W/CONN – 16"
	1	146768	CELL-SW 21"-15FT W/CONN – 24" & 33.5"
	1	406699	CELL-SW 13"-15FT W/ CABLE GUARD
	1	405104	CELL-SW 21"-15FT W/ CONN AND CABLE GUARD
4	4	146760	MOUNT-ELASTOMER
5	1	404211	CLAMP-CABLE .25ID SS
6	1	403392	STRAP-LOADCELL COVER
7	1	403394	COVER-LOADCELL DUST
8	8	146764	NUT-3/8-24 UNF SS
9	4	840468	CONNECTOR – PIN /MALE
10	1	840469	CONNECTOR BODY/MALE (SEE PAGE 23 FOR WIRING DIAGRAM)
11	1	141603	HEAT SHRINK .75"
12	10	404790	CABLE GUARD

STOCK WEIGH 6600

W/O CABLE GUARD

400058
400006

SW 6600 – 33.5”
SW 6600 – 44”

W/ CABLE GUARD

407025
407022

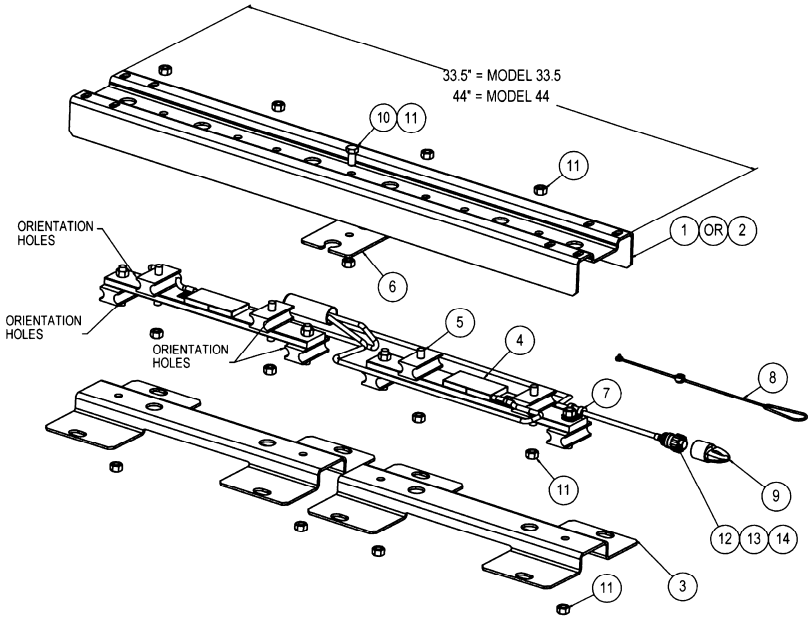

KEY	QTY	PART NO	DESCRIPTION
1	1	400059	CHANNEL-33.5” SW 6600 UPPER
2	1	400010	CHANNEL-44” SW 6600 UPPER
3	2	400031	CHANNEL-16” SW 3300 LOWER
4	1	400005	CELL-SW 13”-15 FT CORD W/ CONNECTOR
	1	407019	CELL-SW 13”-15 FT W/ CABLE GUARD
5	8	146760	MOUNT-ELASTOMER
6	1	404212	CABLE-LOOP RETAINER
7	1	404211	CLAMP-CABLE .25 ID SS
8	1	403392	STRAP-LOAD CELL COVER
9	1	403394	COVER-LOADCELL DUST
10	1	400303	HEX HEAD CAP SCREW3/824 SS
11	17	146764	NUT-3/8-24 UNF SS
12	4	840468	CONNECTOR – PIN /MALE
13	1	840469	CONNECTOR BODY/MALE (SEE PAGE 23 FOR WIRING DIAGRAM)
14	1	141603	HEAT SHRINK .75”

STOCK WEIGH 6600

W/O CABLE GUARD

403444

SW 6600 PAIRED 16" MNT

W/ CABLE GUARD

407032

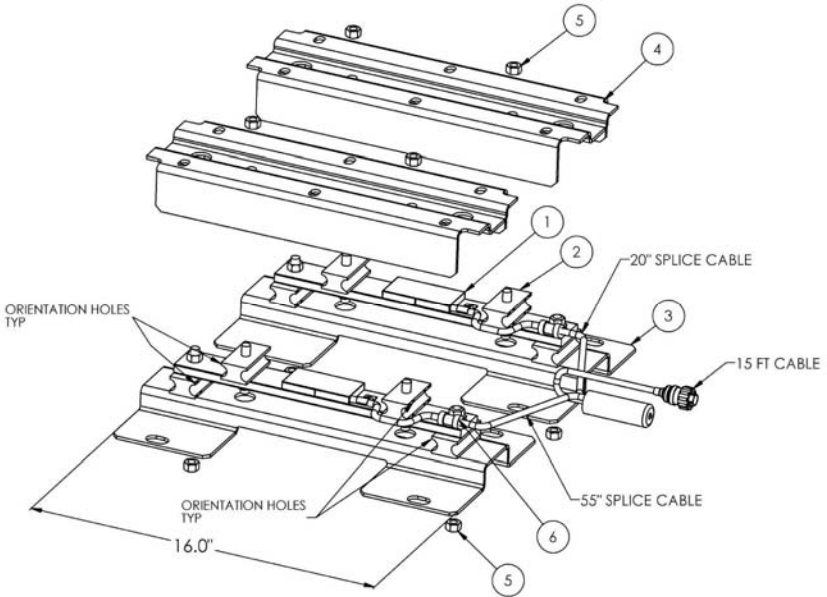

KEY	QTY	PART NO	DESCRIPTION
1	1	403440	CELL-SW PR 13"-15FT W/ CONNECTOR
	1	407039	CELL-SW PR 13"-15FT W/ CABLE GUARD
2	8	146760	MOUNT ELASTOMER
3	2	400031	CHANNEL-16" SW 3300 LOWER
4	2	148039	CHANNEL-16" SW 3300 UPPER
5	16	146764	NUT-3/8-24 UNF SS
6	2	404211	CLAMP-CABLE .25 ID SS

STOCK WEIGH – 10,000 LBS

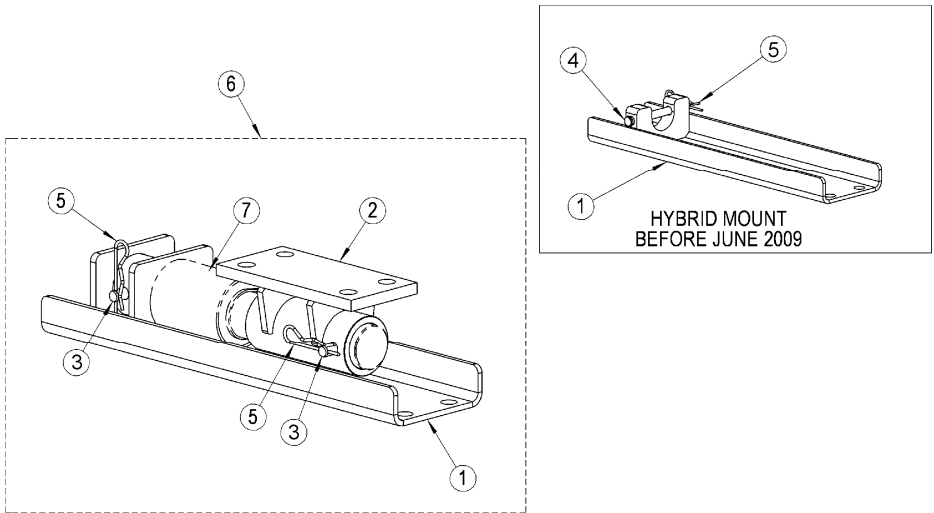

KEY	QTY	PART NO	DESCRIPTION
1	1	404875	WELD-10K LOWER MTG SUPPT
	1	404964	WELD-10K LOWER MTG SUPPT HYBRID (OBSOLETE ORDER 404875)
2	1	404874	WELD-UPPER MTG 1.5 ID
3	1	403664	PIN - 3/8 X 2-1/2 CLEVIS SS
4	1	404976	PIN-CLEVIS 3/8 X 4.0 SS
5	2	405094	PIN-HAIR CLIP 3/32 X 2-1/2
6	1	405536	PACK – 10K MOUNT
7	1	403138	CELL – SW PAIR 1.5DB (REF, ORDER SEPARATE)
	1	407056	CELL – SW PAIR 1.5DB W/ CABLE GUARD
	1	400400	CELL – 1.5DB 10K (REF, ORDER SEPARATE)
	1	407055	CELL – 1.5DB 10K W/ CABLE GUARD

STOCK WEIGH – 14,000 LBS

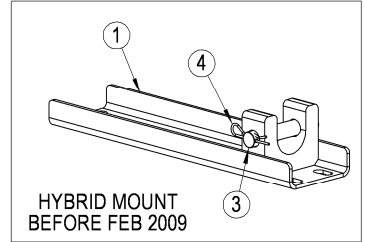
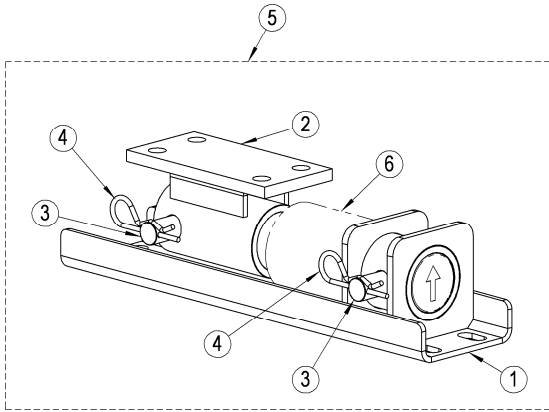

KEY	QTY	PART NO	DESCRIPTION
1	1	405089	WELD-14K LOWER CHANNEL
	1	405135	WELD-14K LOWER CHANNEL HYBRID (OBSOLETE ORDER 405089)
2	1	405088	WELD-14K UPPER MNT
3	2	405137	PIN-CLEVIS 3/4 X 4.0 SS
4	2	405094	PIN-HAIR CLIP 3/32 X 2-1/2
5	1	405537	PACK – 14K MOUNT
6	1	403857	CELL – SW PAIR 1.875DB 14K (REF, ORDER SEPARATE)
	1	407057	CELL – SW PAIR 1.875 DB W/ CABLE GUARD
	1	153171	CELL – 1.875DB 14K (REF, ORDER SEPARATE)
	1	407058	CELL – 1.875 DB 14K W/ CABLE GUARD

J-BOX REPAIR PARTS
 P/N 404254 Assy J-box 4pt mobile
 P/N 404256 Assy J-box 6pt mobile
 (4pt Mobile J-box is shown)

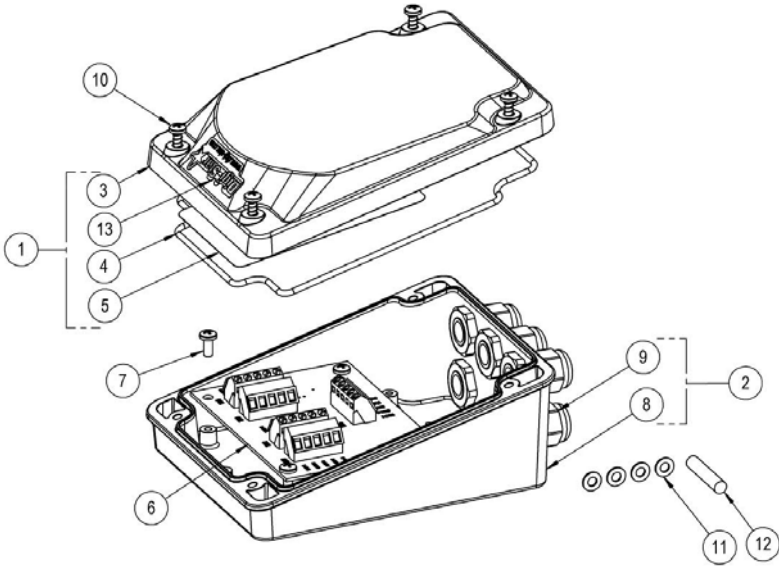

KEY	PART NO.	DESCRIPTION
1	404257	TOP COVER ASSEMBLY (INCLUDES KEYS 3-5, 13)
2	404258	BOTTOM HOUSING ASSEMBLY – 3PT/4PT MOBILE (INCLUDES KEYS 8, 9)
	404261	BOTTOM HOUSING ASSEMBLY – 6 PT MOBILE (INCLUDES KEYS 8, 9)
3	404084	HOUSING TOP COVER
4	404082	GASKET-J-BOX .106 DIA
5	404283	DECAL-J-BOX WIRING
6	148051	PC BOARD ASSEMBLY-COMPLETE 3PT/4PT
	404275	PC BOARD ASSEMBLY-COMPLETE 6PT
7	404616	SCR-#8 X 3/8 PH HI/LOW ZP
8	404083	BOTTOM HOUSING 3PT/4PT
	404158	BOTTOM HOUSING 6PT W/DRILLED HOLES
9	141885	STRAIN RELIEF HEYCO
10	404160	SCR-#8 X 1.0 PHSTS SS
11	404217	WASHER-#8 SMALL OD FLAT SS
12	146724	ROD-1/4" PLASTIC HEYCO PLUG
13	404486	DECAL DIGI-STAR (.8" X 1.9")

J-BOX REPAIR PARTS
P/N 404930 Assy Lever Nut J-box

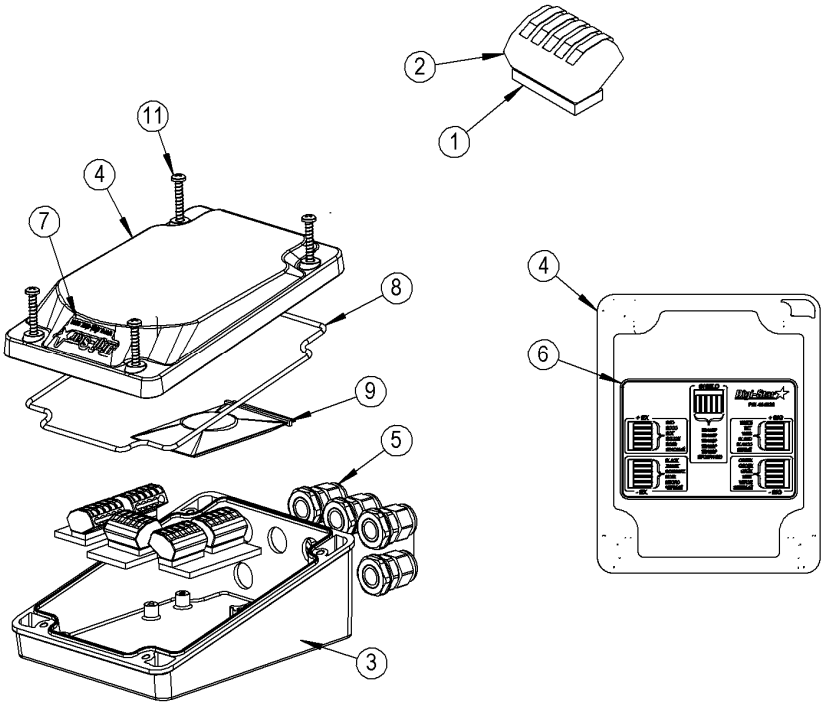

KEY	QTY	PART NO	DESCRIPTION
1	8"	148185	FASTENER- HOOK & LOOP
2	5	404927	TERMINAL-LEVER-LOCK 5 POS
3	1	404083	HSG-J BOX BOTTOM
4	1	404084	HSG-J BOX TOP
5	5	141885	RELIEF - STRAIN HEYCO
6	1	404928	DECAL LEVER-NUT WIRING INSTR
7	1	404486	DECAL-DIGI-STAR BLUE
8	1	404082	GASKET-J-BOX HSG .106 DIA
9	1	404347	PACK J-BOX MTG HWD
10	1	D3730	MANUAL-LEVER-NUT J-BOX INSTALL
11	4	404160	SCR-#8 X 1.0 PHSTS 48-2 SS

WEDGE MOUNT
P/N 405124 Wedge Mount Socket

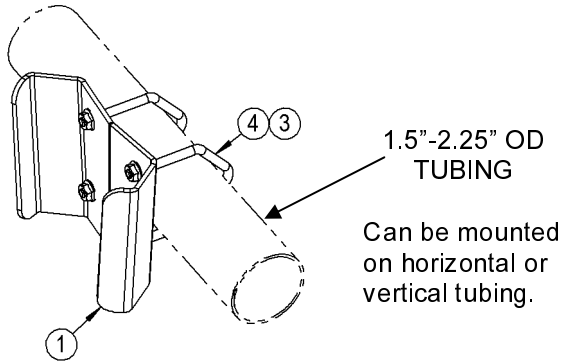

KEY	QTY	PART NO	DESCRIPTION
1	1	405072	BRKT-WEDGE MTG SOCKET
3	2	405069	BOLT-U 1/4-20 X 3.25 ZP
4	4	405084	NUT-1/4-20 TOP LOCK FLANGE ZP

WIRING DIAGRAM - LOAD CELL CONNECTOR

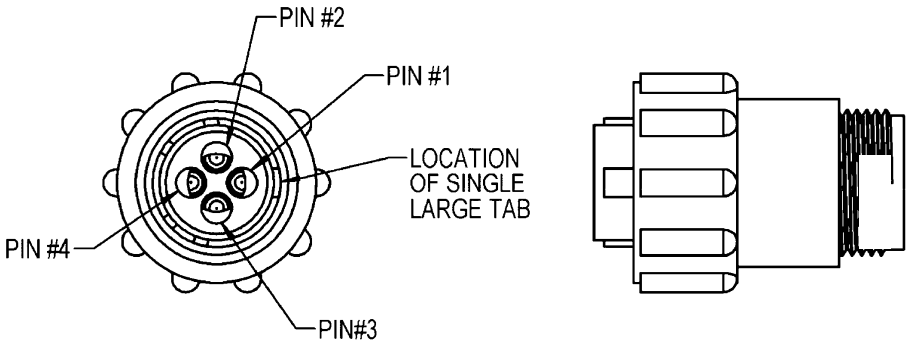

PIN	WIRE COLOR	DESCRIPTION
1	RED	+EX
2	GREEN	-SIG
3	WHITE	+SIG
4	BLACK DRAIN	-EX